

FIGURES

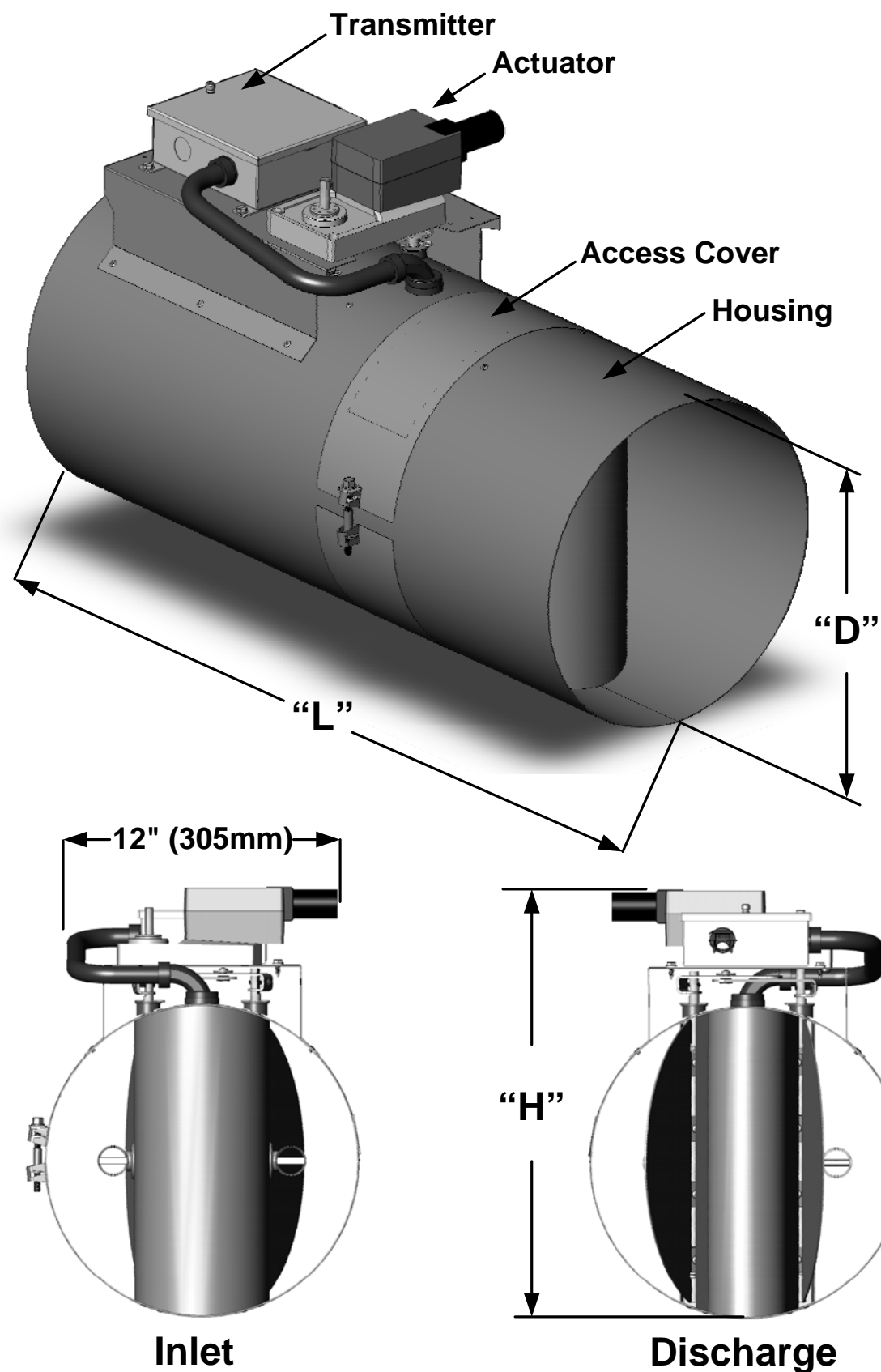

MODEL CODE

AV 3 1 - -

SHAPE

1 = Round

VALVE MATERIAL

- 1 = Galv. Steel, 20 Gauge
- 2 = 304SS, 20 Gauge
- 3 = 316SS, 20 Gauge

ACTUATOR

- 2 = Fail Last Position (0-10v) - Belimo NMQB24-MFT-A FLP
- 3 = Fail Last Position (2-10v) - Belimo NMQB24-MFT-B FLP
- 4 = Fail Open/Closed (0-10v) - Belimo NKQ24-MFT-A FSP
- 5 = Fail Open/Closed (2-10v) - Belimo NKQ24-MFT-B FSP

OPTIONS

- BLANK = No Options
- I = Insulation
- S = Tight Shut-off
- F = Flanges

SIZE

- 06 = 6" Diameter
- 08 = 8" Diameter
- 10 = 10" Diameter
- 12 = 12" Diameter
- 14 = 14" Diameter

NOTES:

- 1) Sensor Material: Polycarbonate Plastic UL94-V0.
- 2) Factory Defaults: Transmitter Output: 2-10v unless otherwise specified. Actuator Options 4&5 set to Fail Open.

SIZE AND WEIGHT

Valve Model	"D"		"L"		"H"		Weight	
	in.	mm	in.	mm	in.	mm	lbs	kg
AV3100-06	5.88	149	22	559	10	254	13	5.9
AV3100-08	7.88	200	24	610	13	381	16	7.3
AV3100-10	9.88	250	24	610	15	432	20	9.1
AV3100-12	11.88	300	27	686	17	483	26	11.8
AV3100-14	13.88	350	30	762	19	533	30	13.6

OPERATING RANGE

Valve Model	Min. Flow		Max. Flow @ .3"wc (75Pa) DP		Max. Flow @ .45"wc (112Pa) DP		Transmitter FS (factory default)	
	CFM	CMH	CFM	CMH	CFM	CMH	CFM	CMH
AV3100-06	30	51	254	432	315	535	330	561
AV3100-08	80	136	650	1104	800	1359	850	1444
AV3100-10	120	204	1056	1794	1300	2209	1370	2328
AV3100-12	180	306	1461	2482	1790	3041	1900	3228
AV3100-14	250	425	2275	3865	2750	4672	3000	5097



Accutrol LLC
600 Pepper Street
Monroe, CT 06468
Tel: 203-445-9991
WWW.ACCUVALVE.COM

SUBMITTAL DRAWING

Round AccuValve® Model AV3100

THIS DOCUMENT IS SUBJECT TO CHANGE WITHOUT NOTICE.
THIS DOCUMENT OR THE CONTENTS THEREOF SHALL NOT BE MODIFIED WITHOUT PRIOR WRITTEN PERMISSION BY ACCUTROL LLC.

DWG. NO:	AV3100 AT SUBMITTAL DWG REV D		
REVISION:	D	ECN:	
REV. DATE:	1-2-12	SHEET:	1 OF: 3

VALVE INSTALLATION INSTRUCTIONS

1. Read all instructions completely before installing the valve.

NOTE: Wear eye protection, protective gloves and clothing suitable for working with sheet metal which may have sharp edges.

2. Verify the tag number located on the valve label matches the HVAC schedule.

3. Select optimum mounting location for the valve.

NOTE: The AccuValve® does not require straight inlet duct runs to operate properly, however it's always best to locate any duct device away from transitions and bends to minimize impact on system static pressure.

4. Allow a minimum clearance of 14 inches (356 mm) unobstructed access to the transmitter, actuator and valve access cover.

5. To support the weight of the valve, install duct hangers within 12 inches (305 mm) of valve connections.

NOTE: Reference Sheet 1 for valve weights.

6. After the duct section is properly supported to carry the valve weight, install the valve into the duct in accordance with the Airflow Direction Label located on the side of the valve. Position the valve so the transmitter, actuator and access cover are easily accessible.

NOTE: The AccuValve® is not position sensitive. It can be installed in any plane or rotational axis without having impact on the factory calibration.

7. Reference the appropriate diagram to the right for installation details.

NOTE: Screws, nuts, fasteners, duct sealant, hangers, companion flanges and gaskets are not provided by Accutrol LLC.

INSTALLATION DIAGRAMS

Figure 1
Standard Slip-fit Valve
Using Sheet Metal
Screws

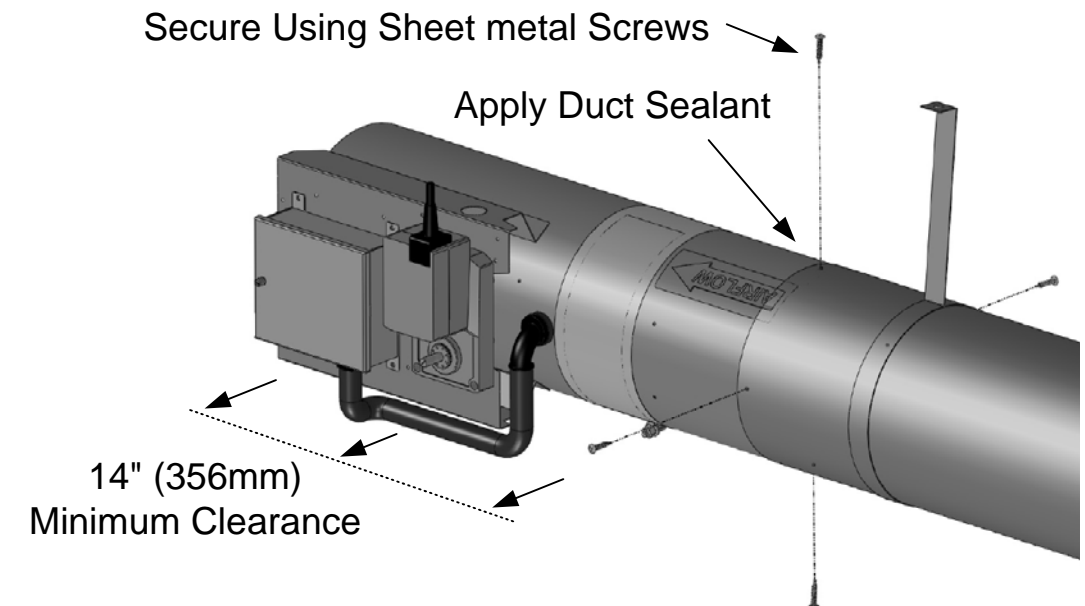

Figure 2
Standard Slip-fit Valve
Using Draw Band
(Purchased Separately)

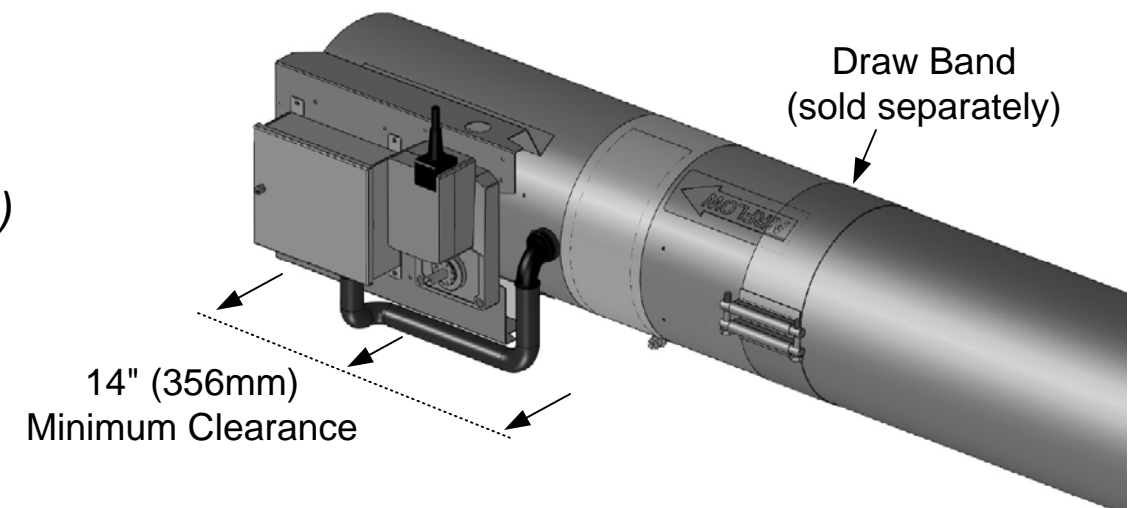
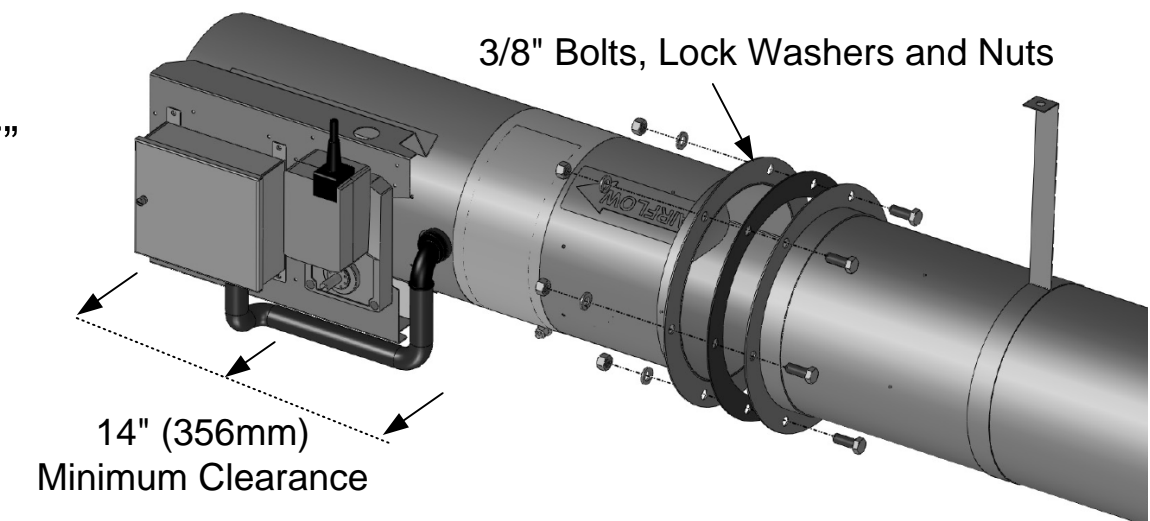

Figure 3
Flanged Valve "Option F"
Using Companion
Flanges



Accutrol LLC
600 Pepper Street
Monroe, CT 06468
Tel: 203-445-9991
WWW.ACCUVALVE.COM

SUBMITTAL DRAWING
Round AccuValve® Model AV3100

THIS DOCUMENT IS SUBJECT
TO CHANGE WITHOUT NOTICE.
THIS DOCUMENT OR THE CONTENTS
THEREOF SHALL NOT BE MODIFIED
WITHOUT PRIOR WRITTEN
PERMISSION BY ACCUTROL LLC.

DWG. NO:	AV3100 AT SUBMITTAL DWG REV D		
REVISION:	D	ECN:	
REV. DATE:	1-2-12	SHEET:	2 OF: 3

WIRING INSTRUCTIONS

Transmitter Wiring

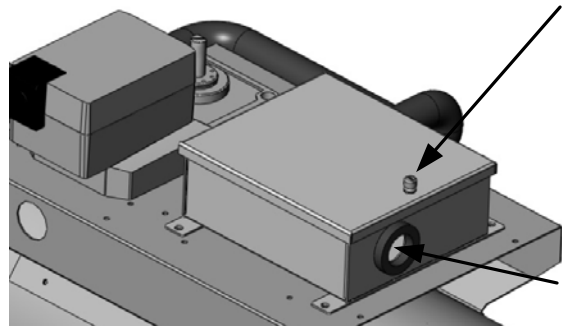

- Loosen the thumb-screw and remove cover.
- Remove the Input Power & Output Signal connectors from board.
- Route Power and Signal cables through the strain relief fitting.

NOTE: For installations requiring conduit, the plastic strain relief fitting can be removed and replaced with .875" (22.2mm) conduit fitting.

- Land wires to the appropriate terminals, secure terminal block screws and reinstall the connectors to their respective locations.

NOTE: Reference job-specific wiring diagrams for details of connections to field devices.

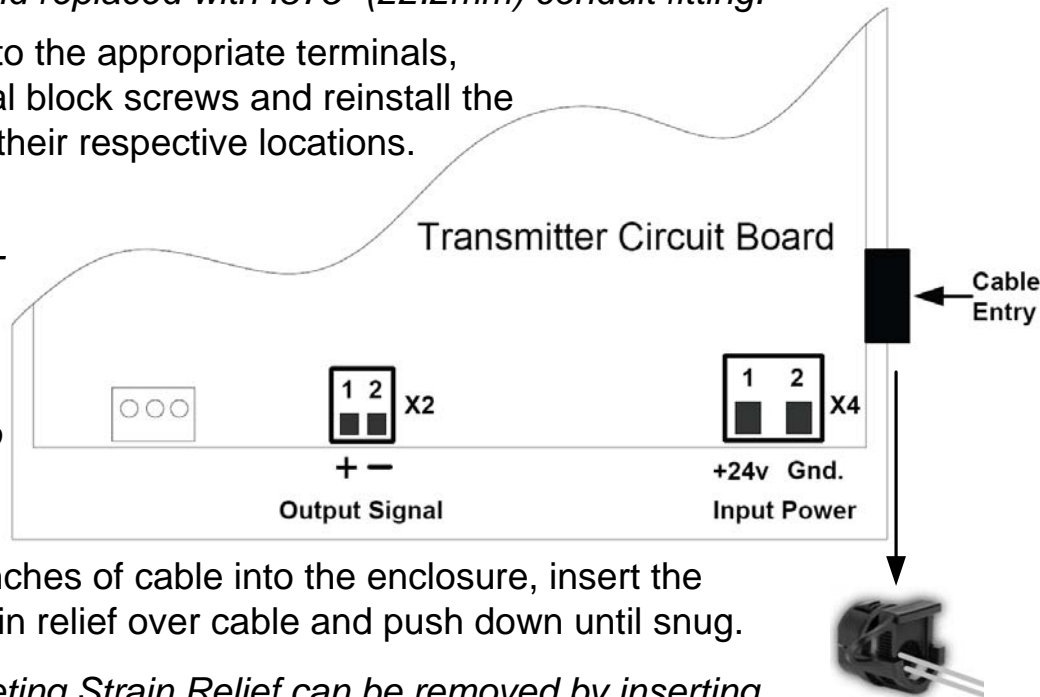

- Pull a few inches of cable into the enclosure, insert the ratcheting strain relief over cable and push down until snug.

NOTE: Ratcheting Strain Relief can be removed by inserting snap ring pliers with .040" tips into two holes on the part and spread open.

- Reinstall the cover and secure by tightening the thumb screw.

Actuator Wiring

Basic wiring requirements for the actuator are shown in the wiring diagram to the right. For more details, reference the AV3000 Operation & Maintenance Manual.

WIRING DIAGRAMS

Figure 1, Typical Field Wiring Schematic

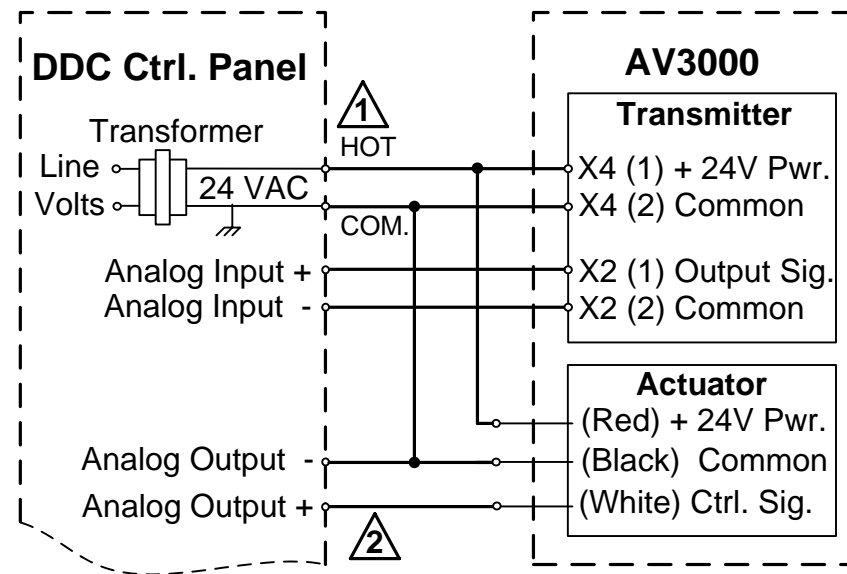
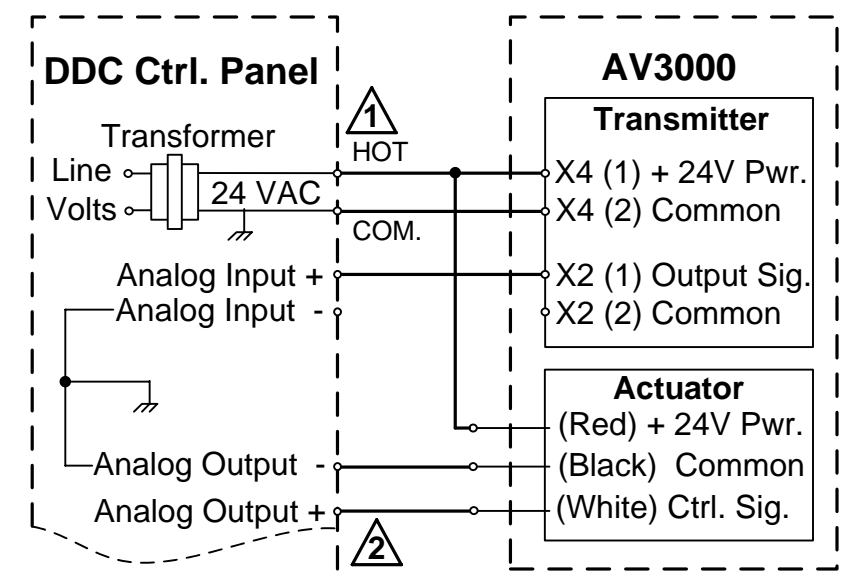

Figure 2, Controller with Common I/O and Power Ground



NOTES:

- 1** Polarity must be maintained if transformer is used to power multiple devices otherwise equipment may be damaged. Power source must include a circuit breaker and be current limited to 8 amps maximum and grounded on the (-) side.
- 2** Wiring shown is for (2-10 VDC or 0-10 VDC) Analog Output. For using a current Analog Output (4-20mA or 0-20mA) install a 500-ohm 1/4 watt resistor across Analog Output + and - terminals at the Controller.
- Figures 1 and 2 are intended to be used as a general guide for wiring the AV3000 to a typical DDC Controller. The detailed wiring diagrams provided by the Control Contractor shall be used in conjunction with this document.
- Power Requirements: Transmitter (2.5 VA), Actuator (23 VA).

ELECTRICAL SPECIFICATIONS

Transmitter Electrical Specifications

Input Power: 24 VAC +/- 20% 50/60 Hz, 2.5 VA Max. or 24 VDC +/- 20%, 75mA Max.

Output Signal: 0-10v, 2-10v, 0-20mA or 4-20mA (Configurable Using Jumpers JP1 and JP4)

Wire Specifications: 16-22 AWG, Shielded Cable

Electromagnetic Compatibility: EMC Directive 2004/108/EC, Low Voltage Directive 2004/108/EEC, EN61326-1:2006, FCC Part 15

Product Safety: IEC/EN/UL/CSA 61010-1:2001, CAN/CSA-C22.2 No. 61010-1



Actuator Electrical Specifications

Reference the AV3000 Operation & Maintenance Manual for actuator's electrical specifications.



Accutrol LLC
600 Pepper Street
Monroe, CT 06468
Tel: 203-445-9991
WWW.ACCUVALVE.COM

SUBMITTAL DRAWING
Round AccuValve® Model AV3100

THIS DOCUMENT IS SUBJECT TO CHANGE WITHOUT NOTICE. THIS DOCUMENT OR THE CONTENTS THEREOF SHALL NOT BE MODIFIED WITHOUT PRIOR WRITTEN PERMISSION BY ACCUTROL LLC.

DWG. NO:	AV3100 AT SUBMITTAL DWG REV D		
REVISION:	D	ECN:	
REV. DATE:	1-2-12	SHEET:	3 OF: 3