

# FIGURES

AV3200-18, -24

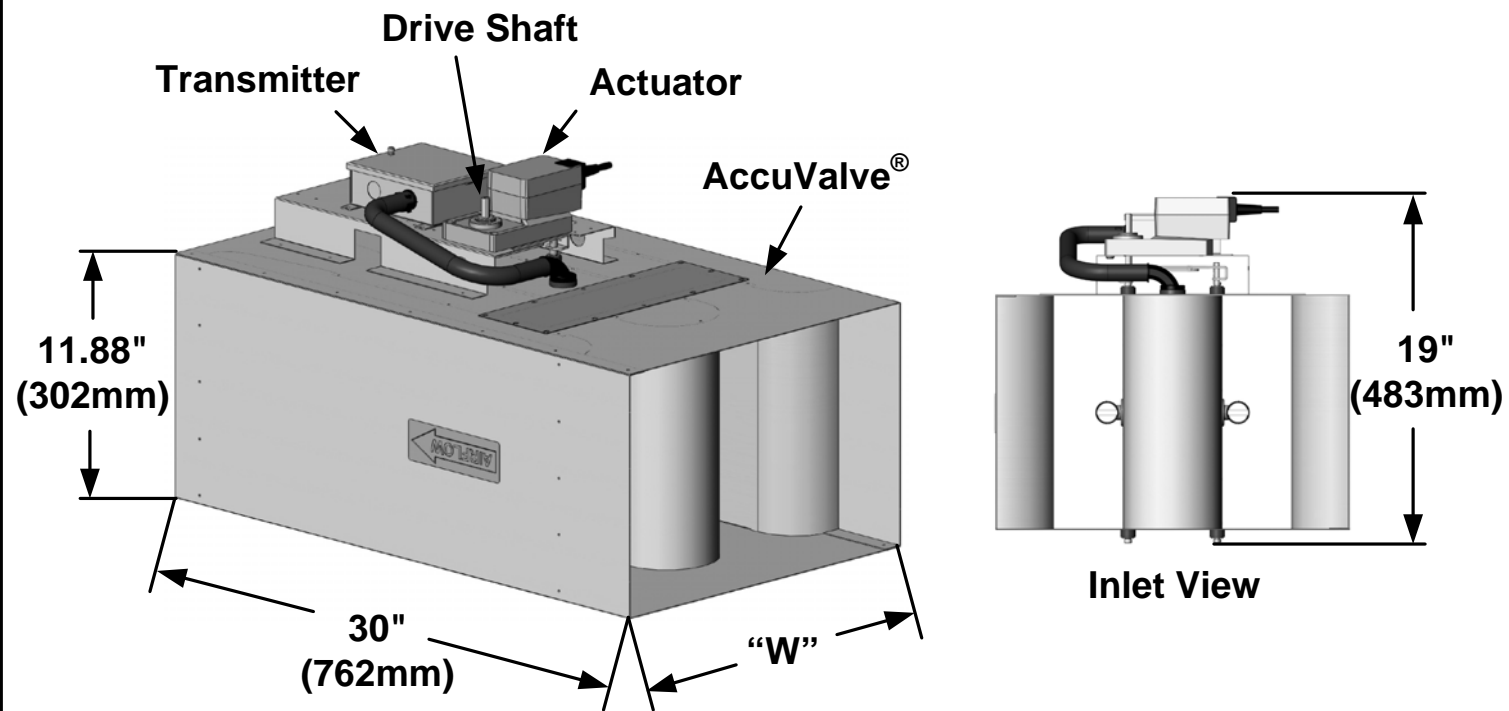

AV3200-36, -48

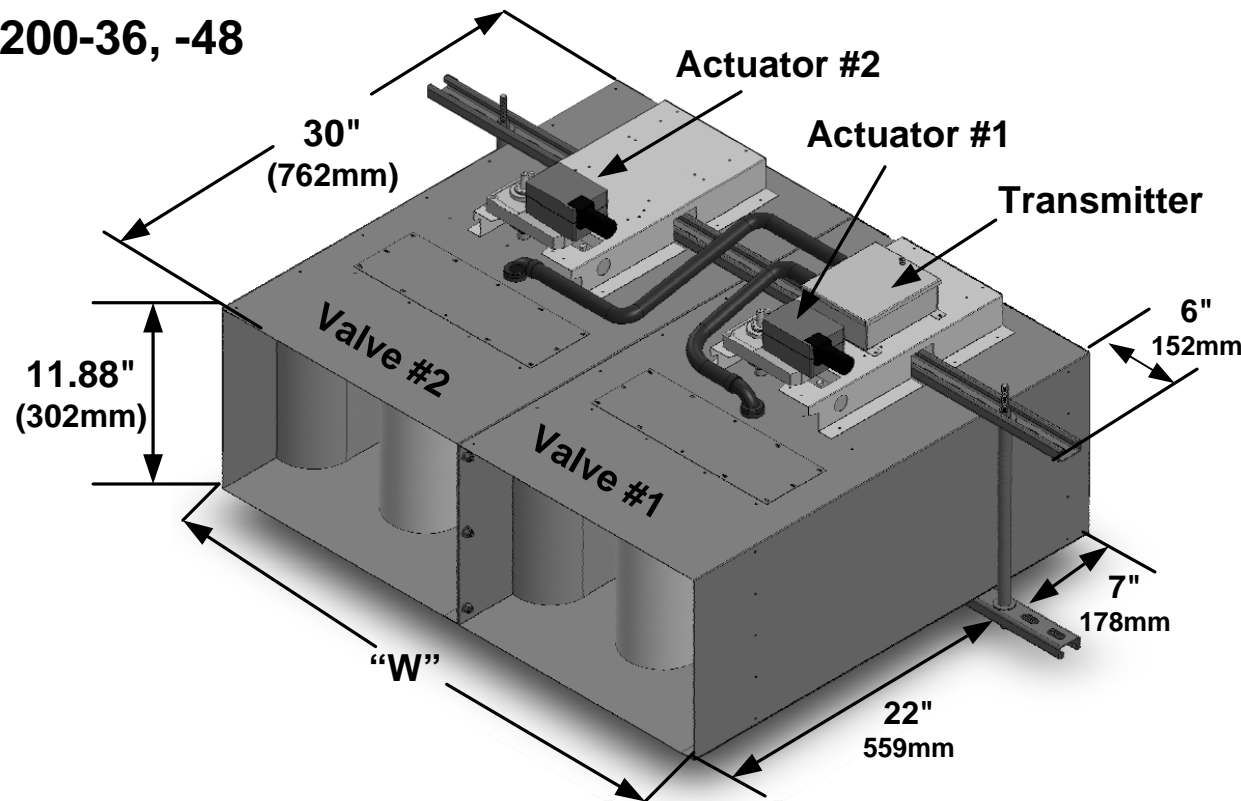

# MODEL CODE

AV 3 2 - - -

**SHAPE**  
2 = Rectangular

**VALVE MATERIAL**  
1 = Galv. Steel, 20 Gauge  
2 = 304SS, 20 Gauge  
3 = 316SS, 20 Gauge

**ACTUATOR**  
2 = Fail Last Position (0-10v) - Belimo NMQB24-MFT-A FLP  
3 = Fail Last Position (2-10v) - Belimo NMQB24-MFT-B FLP  
4 = Fail Open/Closed (0-10v) - Belimo NKQ24-MFT-A FSP  
5 = Fail Open/Closed (2-10v) - Belimo NKQ24-MFT-B FSP

**OPTIONS**  
BLANK = No Options  
I = Insulation  
F = Flanges

**SIZE**  
18 = 12" h x 18" w  
24 = 12" h x 24" w  
36 = 12" h x 36" w  
48 = 12" h x 48" w

**NOTES:**

- 1) Sensor Material: Polycarbonate Plastic UL94-V0.
- 2) Factory Defaults: Transmitter Output: 2-10v unless otherwise specified. Actuator Options 4&5 set to Fail Open.

# SIZE AND WEIGHT

Valve Model	"W"		Weight	
	In.	mm	Lbs.	kg
AV3200-18	17.88	454	43	19.5
AV3200-24	23.88	607	49	22.2
AV3200-36	35.88	911	97	44.0
AV3200-48	47.88	1216	109	49.4

# OPERATING RANGE

Valve Model	Min. Flow		Max. Flow @ .3"wc (75Pa) DP		Max. Flow @ .45"wc (112Pa) DP		Transmitter FS (factory default)	
	CFM	CMH	CFM	CMH	CFM	CMH	CFM	CMH
AV3200-18	260	442	2596	4411	3200	5437	3400	5777
AV3200-24	350	595	3237	5500	4000	6796	4200	7136
AV3200-36	520	883	5191	8820	6400	10874	6800	11553
AV3200-48	700	1189	6473	10998	8000	13592	8400	14272



Accutrol LLC  
600 Pepper Street  
Monroe, CT 06468  
Tel: 203-445-9991  
WWW.ACCUVALVE.COM

**SUBMITTAL DRAWING**  
Rectangular AccuValve® Model AV3200

THIS DOCUMENT IS SUBJECT TO CHANGE WITHOUT NOTICE. THIS DOCUMENT OR THE CONTENTS THEREOF SHALL NOT BE MODIFIED WITHOUT PRIOR WRITTEN PERMISSION BY ACCUTROL LLC.

DWG. NO:	AV3200 AT SUBMITTAL DWG REV C		
REVISION:	C	ECN:	
REV. DATE:	1-2-12	SHEET:	1 OF: 3

# VALVE INSTALLATION INSTRUCTIONS

1. Read all instructions completely before installing the valve.  
**NOTE:** Wear eye protection, protective gloves and clothing suitable for working with sheet metal which may have sharp edges.
2. Verify the tag number located on the valve label matches the HVAC schedule.
3. Select optimum mounting location for the valve.  
**NOTE:** The AccuValve® does not require straight inlet duct runs to operate properly, however it's always best to locate any duct device away from transitions and bends to minimize impact on system static pressure.
4. Allow a minimum clearance of 14 inches (356 mm) unobstructed access to the transmitter, actuator and valve access cover.  
**NOTE:** Rectangular valves are normally installed with the "access side" facing downwards for easy access. However, The AccuValve® is not position sensitive. It can be installed in any plane or rotational axis without having impact on the factory calibration
5. To support the weight of the valve, install duct hangers within 12 inches (305 mm) of valve connections. The 12"x36" and 12"x48" valves include an integral mounting bracket which shall be used to support valve in addition to the duct hangers.  
**NOTE:** Reference Sheet 1 for valve weights.
6. After the duct section is properly supported to carry the weight of the valve, install valve into the duct in accordance with the Airflow Direction Label located on the side of the valve. Position valve so the transmitter, actuator and access cover are easily accessible. For 12x36" and 12x48" valves, attach the integral mounting bracket to threaded rod or duct hangers capable of supporting valve weight.
7. Reference the appropriate diagram to the right for installation details.  
**NOTE:** Screws, nuts, fasteners, duct sealant, hangers, companion flanges and gaskets are not provided by Accutrol LLC.

# INSTALLATION DIAGRAMS

**Figure 1**  
Standard Slip-fit Valve Using Sheet Metal Screws

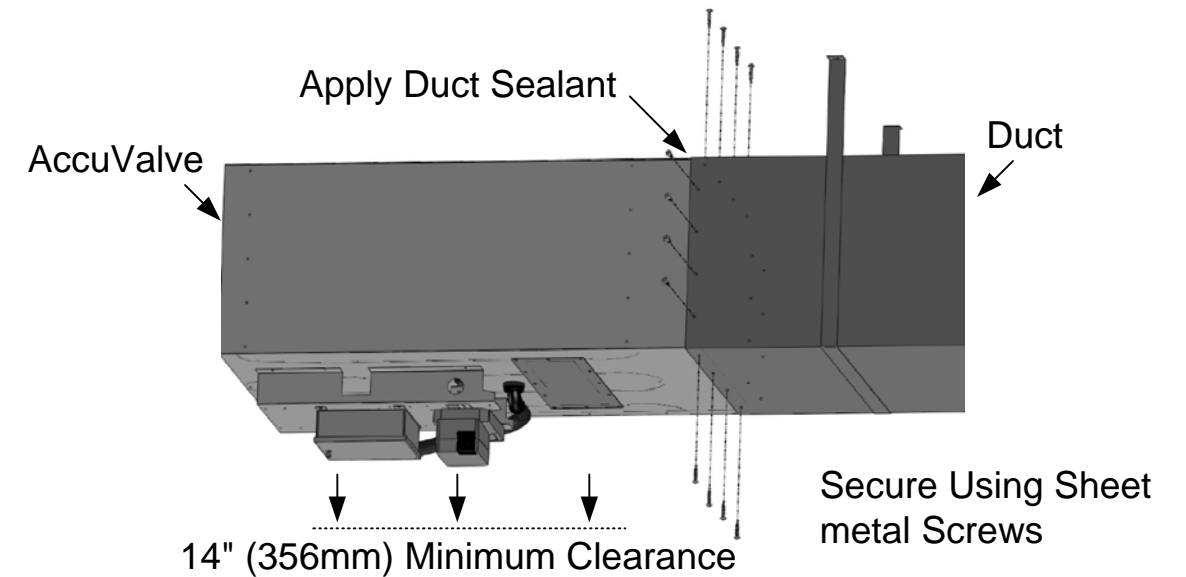

**Figure 2**  
Flanged Valve "Option F" Using Companion Flanges

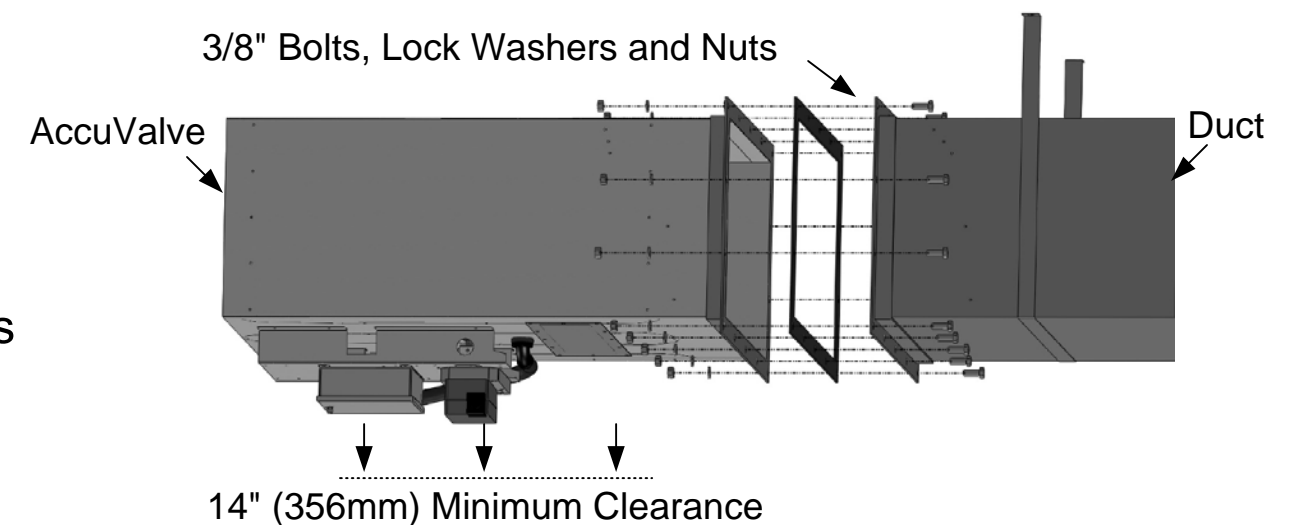

**Figure 3**  
12x36" and 12x48" Valves

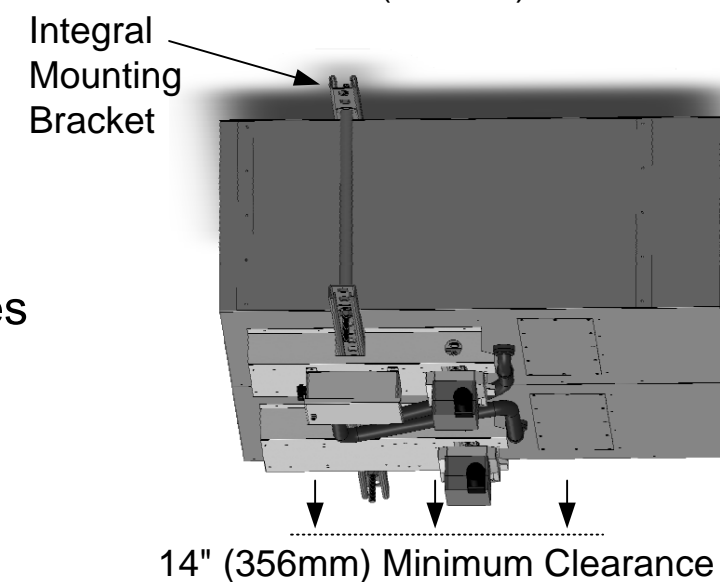

**NOTE:** Dual valves are provided with an integral mounting bracket to help support the weight of the valve. In addition to supporting the duct within 12" of the valve, each end of the integral mounting bracket shall be secured to the building structure using properly rated hardware and methods in accordance with local building codes.



Accutrol LLC  
600 Pepper Street  
Monroe, CT 06468  
Tel: 203-445-9991  
WWW.ACCUVALVE.COM

**SUBMITTAL DRAWING**  
**Rectangular AccuValve® Model AV3200**

THIS DOCUMENT IS SUBJECT TO CHANGE WITHOUT NOTICE. THIS DOCUMENT OR THE CONTENTS THEREOF SHALL NOT BE MODIFIED WITHOUT PRIOR WRITTEN PERMISSION BY ACCUTROL LLC.

DWG. NO:	AV3200 AT SUBMITTAL DWG REV C		
REVISION:	C	ECN:	
REV. DATE:	1-2-12	SHEET:	2 OF: 3

# WIRING INSTRUCTIONS

## Transmitter Wiring

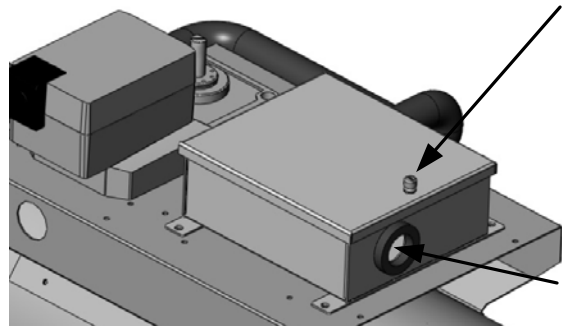

1. Loosen the thumb-screw and remove cover.
2. Remove the Input Power and Output Signal connectors from board.
3. Route Power and Signal cables through the strain relief fitting.

**NOTE:** For installations requiring conduit, the plastic strain relief fitting can be removed and replaced with .875" (22.2mm) conduit fitting.

4. Land wires to the appropriate terminals, secure terminal block screws and reinstall the connectors to their respective locations.

**NOTE:** Reference job-specific wiring diagrams for details of connections to field devices.

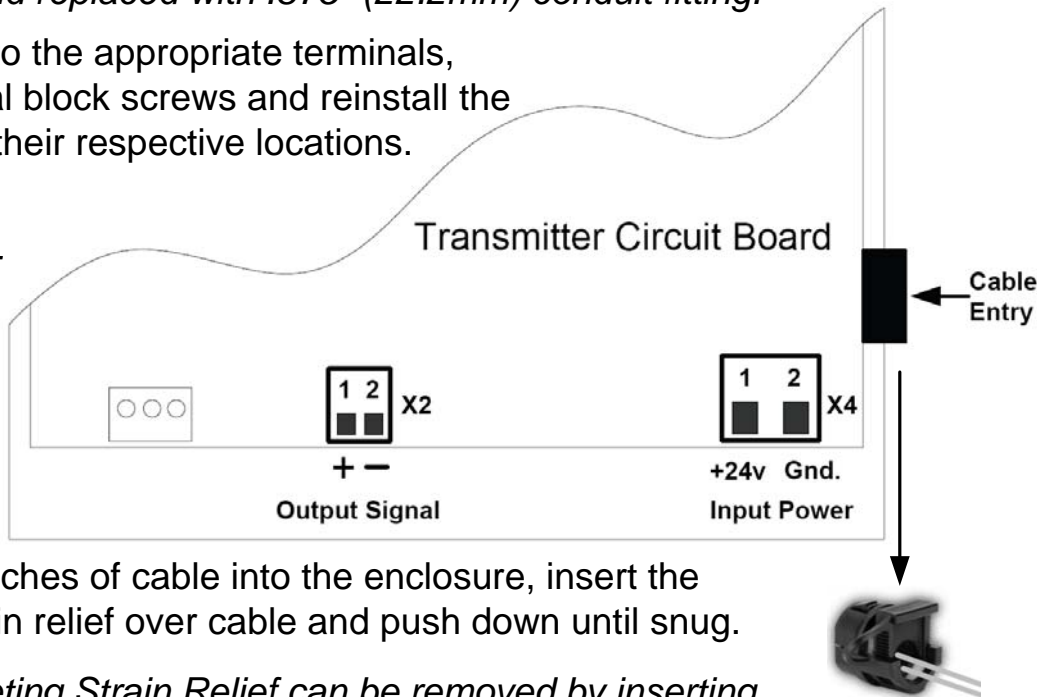

5. Pull a few inches of cable into the enclosure, insert the ratcheting strain relief over cable and push down until snug.

**NOTE:** Ratcheting Strain Relief can be removed by inserting snap ring pliers with .040" tips into two holes on the part and spread open.

6. Reinstall the cover and secure by tightening the thumb screw.

## Actuator Wiring

Basic wiring requirements for the actuator are shown in the wiring diagram to the right. For more details, reference the AV3000 Operation & Maintenance Manual.

# WIRING DIAGRAMS

Figure 1, Typical Field Wiring Schematic

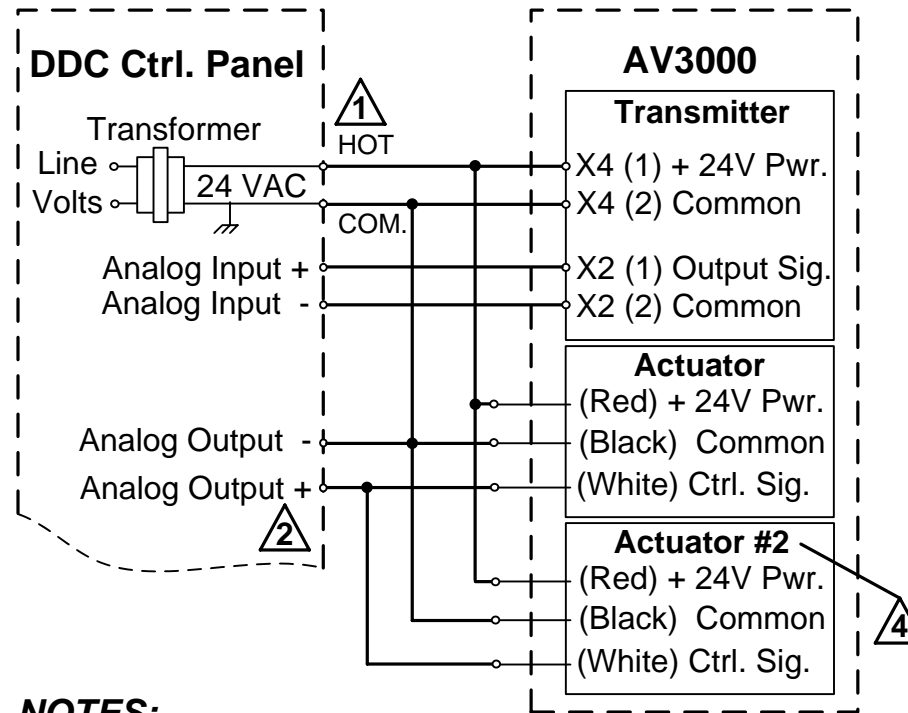

### NOTES:

1. Polarity must be maintained if transformer is used to power multiple devices otherwise equipment may be damaged. Power source must include a circuit breaker and be current limited to 8 amps maximum and grounded on the (-) side.
2. Wiring shown is for (2-10 VDC or 0-10 VDC) Analog Output. For using a current Analog Output (4-20mA or 0-20mA) install a 500-ohm ¼ watt resistor across Analog Output + and - terminals at the Controller.
3. Figures 1 and 2 are intended to be used as a general guide for wiring the AV3000 to a typical DDC Controller. The detailed wiring diagrams provided by the Controls Contractor shall be used in conjunction with this document.
4. Actuator #2 is used for 12x36" and 12x48" valves only.
5. Power Requirements: Transmitter (2.5 VA), Actuator (23 VA).

Figure 2, Controller with Common I/O and Power Ground

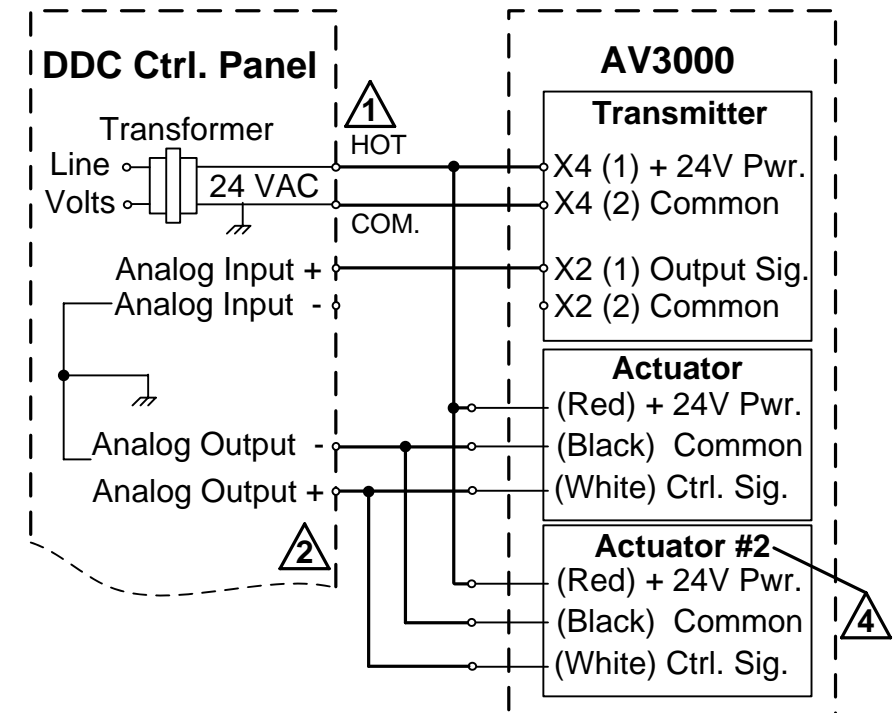

# ELECTRICAL SPECIFICATIONS

## Transmitter Electrical Specifications

Input Power: 24 VAC +/- 20% 50/60 Hz, 2.5 VA Max. or 24 VDC +/- 20%, 75mA Max.

Output Signal: 0-10v, 2-10v, 0-20mA or 4-20mA (Configurable Using Jumpers JP1 and JP4)

Wire Specifications: 16-22 AWG, Shielded Cable

Electromagnetic Compatibility: EMC Directive 2004/108/EC, Low Voltage Directive 2004/108/EEC, EN61326-1:2006, FCC Part 15

Product Safety: IEC/EN/UL/CSA 61010-1:2001, CAN/CSA-C22.2 No. 61010-1



## Actuator Electrical Specifications

Reference the AV3000 Operation & Maintenance Manual for actuator's electrical specifications.



Accutrol LLC  
600 Main Street  
Monroe, CT 06468  
Tel: 203-445-9991  
WWW.ACCUVALVE.COM

**SUBMITTAL DRAWING**  
**Rectangular AccuValve® Model AV3200**

THIS DOCUMENT IS SUBJECT TO CHANGE WITHOUT NOTICE. THIS DOCUMENT OR THE CONTENTS THEREOF SHALL NOT BE MODIFIED WITHOUT PRIOR WRITTEN PERMISSION BY ACCUTROL LLC.

DWG. NO:	AV3200 AT SUBMITTAL DWG REV C		
REVISION:	C	ECN:	
REV. DATE:	1-2-12	SHEET:	3 OF 3