

MODEL VSS-50

The Vertical Sash Sensor (VSS) is a Cable Extension Position Transducer that produces an electrical output signal proportional to cable extension. The VSS is installed onto the fume hood with its extension cable attached to the vertical rising fume hood sash or counterweight cable. As the sash moves up and down, the cable extends and retracts, providing an electrical signal that accurately depicts the sash position.

INSTALLATION

The following instructions are provided as a guideline for installing the VSS-50 onto a fume hood. Because fume hood construction varies greatly, additional hardware not provided by Accutrol may be required for some applications.

Regardless of which installation method is used, the VSS shall be installed and secured to the fume hood using the mounting screws provided. The retractable cable end can be attached to the counterweight, the counterweight cable or the vertical sash frame. The basic steps required for each type of installation are similar, however the hardware required may vary due to the specific application.

WARNING: Do not allow the wire rope to “snap back” into the VSS otherwise damage to the part and personal injury can result.

1. Select a suitable location to attach the retracting cable on either the sash frame, counterweight or counterweight cable system. Following are some guidelines to follow for determining a suitable location.

- If you plan on attaching the extension cable end to a counterweight cable, verify there is enough distance between pulleys to account for the full sash travel. The sensor cable should not travel over counterweight pulleys or sprockets.
- Verify the cable will not rub or chafe against any surface during sash movement.
- As the sash is moved in one direction, the extension cable shall only move in one direction in relation to the VSS.

For example, if the VSS is installed on top of the hood and the extension cable is secured to the sash frame, the extension cable shall NOT pass by the VSS during sash movement.

Figure 1A shows an acceptable location for securing the extension cable in relation to the VSS-50. As the sash is raised and lowered, the extension cable end never passes by the VSS.

Figure 1B shows an unacceptable location for securing the extension cable in relation to the VSS-50. As the sash is raised, the extension cable retracts until it passes by the VSS-50 where it changes direction and begins to extend while the sash continues to be raised.

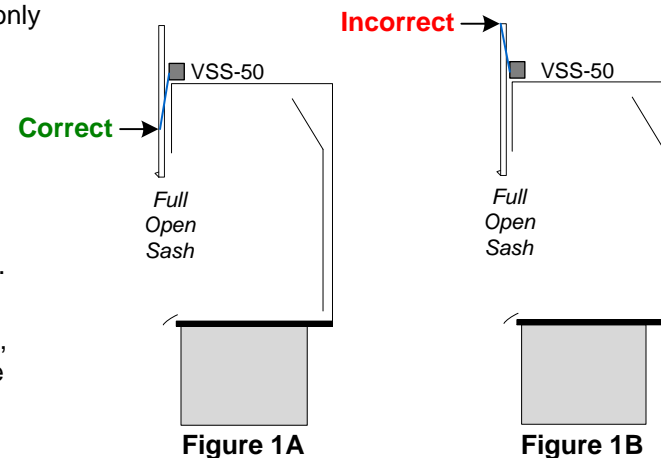

2. Install the VSS to a stationary surface located on the top of the fume hood.

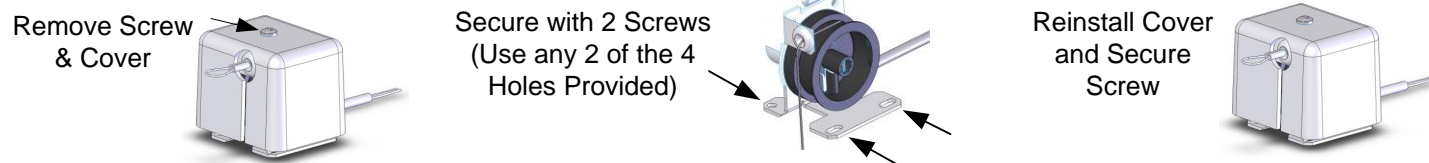

3. Attach the retracting cable to the location selected in Step 1.

4. Slowly raise and lower the sash while observing the VSS and retractable cable to ensure the wire rope extends and retracts straight and without interference to other objects.

DIMENSIONS

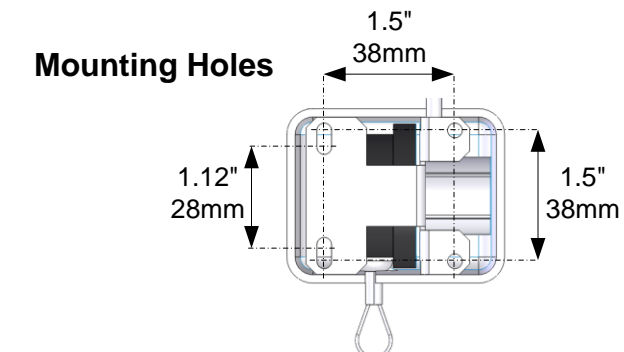
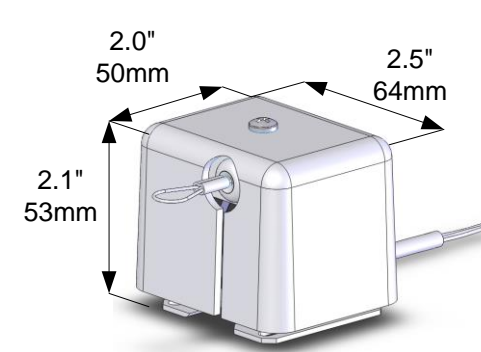

WIRING

WIRING TABLE	
VSS-50	Control Module
Red (+ Signal)	AI-2 (+)
Black (Common)	AI-2 (Gnd)

AVC6000 CONTROL MODULE

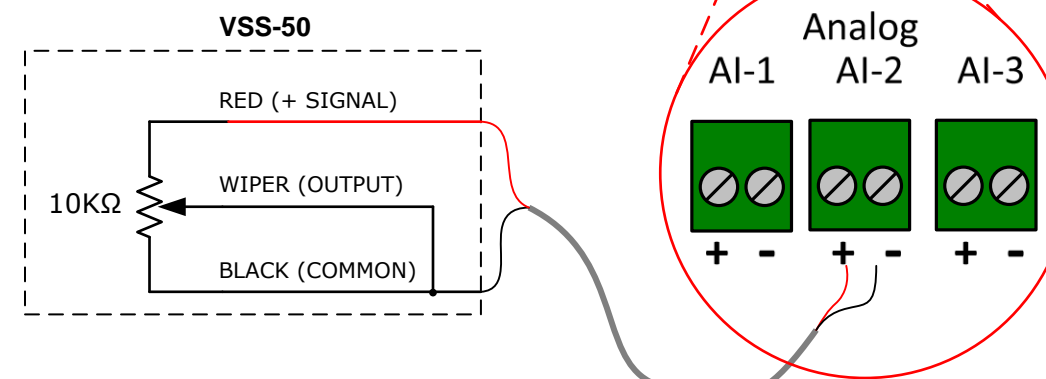
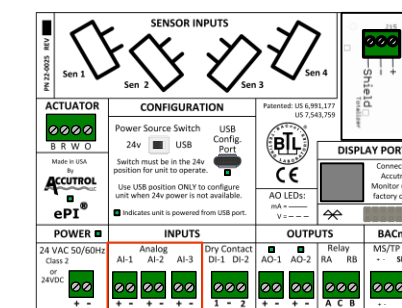

SPECIFICATIONS

- Measurement Range:** 42" (1067mm) max
- Resistance Range:** 0 to 10,000 ohms, Resolution: Essentially Infinite
- Operating Temperature Range:** -13°F to +221°F (-25°C to +105°C)
- Measuring Cable:** Stainless Steel, Nylon Coated, .034" (.086mm) dia.
- Electrical Cable:** 2-cond., 24 Gage, 25 feet (7.6M) Long, PVC Jacket
- Construction:** Mounting Frame is Plated Steel, Removable cover is ABS Plastic
- Life Cycle Rating:** 250,000 Full Cycles Minimum