

# ACCUVALVE® MODEL AVT6000 SUBMITTAL

## MODEL CODE

⚠ **WARNING: NOT FOR USE WITH PERCHLORIC ACID**

AVT6   -  -

### VALVE MATERIAL

(Housing / End Plate & Blades)  
 2 = 304SS / 304SS  
 3 = 316SS / 316SS  
 4 = ALUMINUM / GALVANIZED STEEL  
 6 = 304SS / 304SS (HIGH TEMP VALVE)  
 7 = ALUMINUM / 304SS

### SIZE

06 = 06" DIAMETER  
 08 = 08" DIAMETER  
 10 = 10" DIAMETER  
 12 = 12" DIAMETER  
 14 = 14" DIAMETER  
 18 = 12"x18" RECTANGULAR  
 24 = 12"x24" RECTANGULAR  
 36 = 12"x36" RECTANGULAR  
 48 = 12"x48" RECTANGULAR

### MODEL CODE NOTES:

- 1) Blade seals are standard on all 6" valves, therefore -S option is not available for valve size -06.
- 2) Actuator Type "4 + 5" factory default is set to "fail open".
- 3) Reference the Flange Detail - Vanstone submittal drawing for round flanges
- 4) Reference the Flange Detail - Rectangular submittal drawing for rectangular flanges.
- 5) Insulation is not available on High Temperature AccuValve, Reference the Insulation detail submittal drawing.

### OPTIONS

BLANK = NO OPTIONS  
 A = ACCUNET®  
 B = BACnet MS/TP  
 F = FLANGES (REF NOTES 3 & 4)  
 I = INSULATION (REF NOTE 5)  
 S = TIGHT SHUT-OFF (REF NOTE 1)  
 W = WIRELESS BLUETOOTH

### ACTUATOR

02 = FAIL LAST POSITION (FLP), 0-10V, 2 SEC  
 03 = FAIL LAST POSITION (FLP), 2-10V, 2 SEC  
 04 = FAIL OPEN/CLOSED (FSP), 0-10V, 2 SEC  
 05 = FAIL OPEN/CLOSED (FSP), 2-10V, 2 SEC  
 07 = FAIL LAST POSITION (FLP), 2-10V, 21 SEC

## MATERIALS

Valve Material Code	Materials Exposed to the Airstream				
	(2) 304SS	(3) 316SS	(4) Aluminum	(6) 304SS HIGH TEMP	(7) Aluminum & 304SS
Housing	304L SS (20 GA.)	316L SS (20 GA.)	Alum 5052-H32 (18 GA.)	304L SS (20 GA.)	Alum 5052-H32 (18 GA.)
Compression Section	304L SS (20 GA.)	316L SS (20 GA.)	Alum 5052-H32 (16 GA.)	304L SS (20 GA.)	Alum 5052-H32 (16 GA.)
Static Regain Section	304L SS (20 GA.)	316L SS (20 GA.)	Alum 5052-H32 (18 GA.)	304L SS (20 GA.)	Alum 5052-H32 (18 GA.)
End Plate	304L SS (16 GA.)	316L SS (16 GA.)	Galv. Steel (16 GA.)	304L SS (16 GA.)	304L SS (16 GA.)
Blades	304L SS (16 GA.)	316L SS (16 GA.)	Galv. Steel (16 GA.)	304L SS (16 GA.)	304L SS (16 GA.)
Shafts	316L SS	316L SS	316L SS	316L SS	316L SS
Shaft Bearings	Teflon	Teflon	Teflon	Teflon	Teflon
Vortex Sensors	Polycarbonate Plastic, UL94-V0	Polycarbonate Plastic, UL94-V0	Polycarbonate Plastic, UL94-V0	303 SS	Polycarbonate Plastic, UL94-V0
Sensor Tubing	Polyurethane (Ether-based)	Polyurethane (Ether-based)	Polyurethane (Ether-based)	Viton Rubber	Polyurethane (Ether-based)
Compression Seals	Viton Rubber	Viton Rubber	EPDM Rubber	Viton Rubber	EPDM Rubber
Machine Screws	304 SS	316 SS	304 SS	304 SS	304 SS
Rivets	304 SS	316 SS	304 SS	304 SS	304 SS
Blade Seals (optional)	Viton Rubber	Viton Rubber	EPDM Rubber	Viton Rubber	EPDM Rubber

## OPERATING RANGE

Valve Model	Min. Flow Measured			Full Scale Range		
	CFM	L/S	CMH	CFM	L/S	CMH
AVT6X06-XX	30	14	51	315	149	535
AVT6X08-XX	80	38	136	800	378	1359
AVT6X10-XX	120	57	204	1300	613	2209
AVT6X12-XX	180	85	306	1790	845	3041
AVT6X14-XX	250	118	425	2750	1298	4672
AVT6X18-XX	260	123	442	3200	1510	5437
AVT6X24-XX	350	165	595	4000	1888	6796
AVT6X36-XX	520	245	883	6400	3020	10874
AVT6X48-XX	700	330	1189	8000	3775	13592

Temperature Range				
Valve Material Code	Airstream		Ambient	
	Min. Temp.	Max. Temp.	Min. Temp.	Max. Temp.
2, 3, 4, 7	-20° F (-29° C)	165° F (74° C)	-20° F (-29° C)	125° F (52° C)
6	-20° F (-29° C)	375° F (191° C)	-20° F (-29° C)	125° F (52° C)

## SIZE AND WEIGHT

Valve Model	Valve Dimensions (Reference Sheet 2)						Weight					
	"D" or "W"		"L"		"H"		Stainless Steel		Aluminum		Flange Add	
	in.	mm	in.	mm	in.	mm	Lbs.	kg	Lbs.	kg	Lbs.	kg
AVT6X06-XX	5.88	149	22	559	10	254	13	5.9	9	4.1	2.0	0.9
AVT6X08-XX	7.88	200	24	610	13	330	16	7.3	12	5.4	2.6	1.2
AVT6X10-XX	9.88	250	24	610	15	381	20	9.1	14	6.4	3.2	1.5
AVT6X12-XX	11.88	300	27	686	17	432	26	11.8	16	7.3	4.5	2.0
AVT6X14-XX	13.88	350	30	762	19	483	30	13.6	20	9.1	5.2	2.4
AVT6X18-XX	17.88	454	30	762	19	483	43	19.5	26	11.8	5.0	2.3
AVT6X24-XX	23.88	607	30	762	19	483	49	22.2	29	13.2	5.5	2.5
AVT6X36-XX	35.88	911	30	762	19	483	97	44	59	26.8	10.0	4.5
AVT6X48-XX	47.88	1216	30	762	19	483	109	49.2	69	31.3	11.0	5.0



Accutrol Representative:

## SUBMITTAL DRAWING

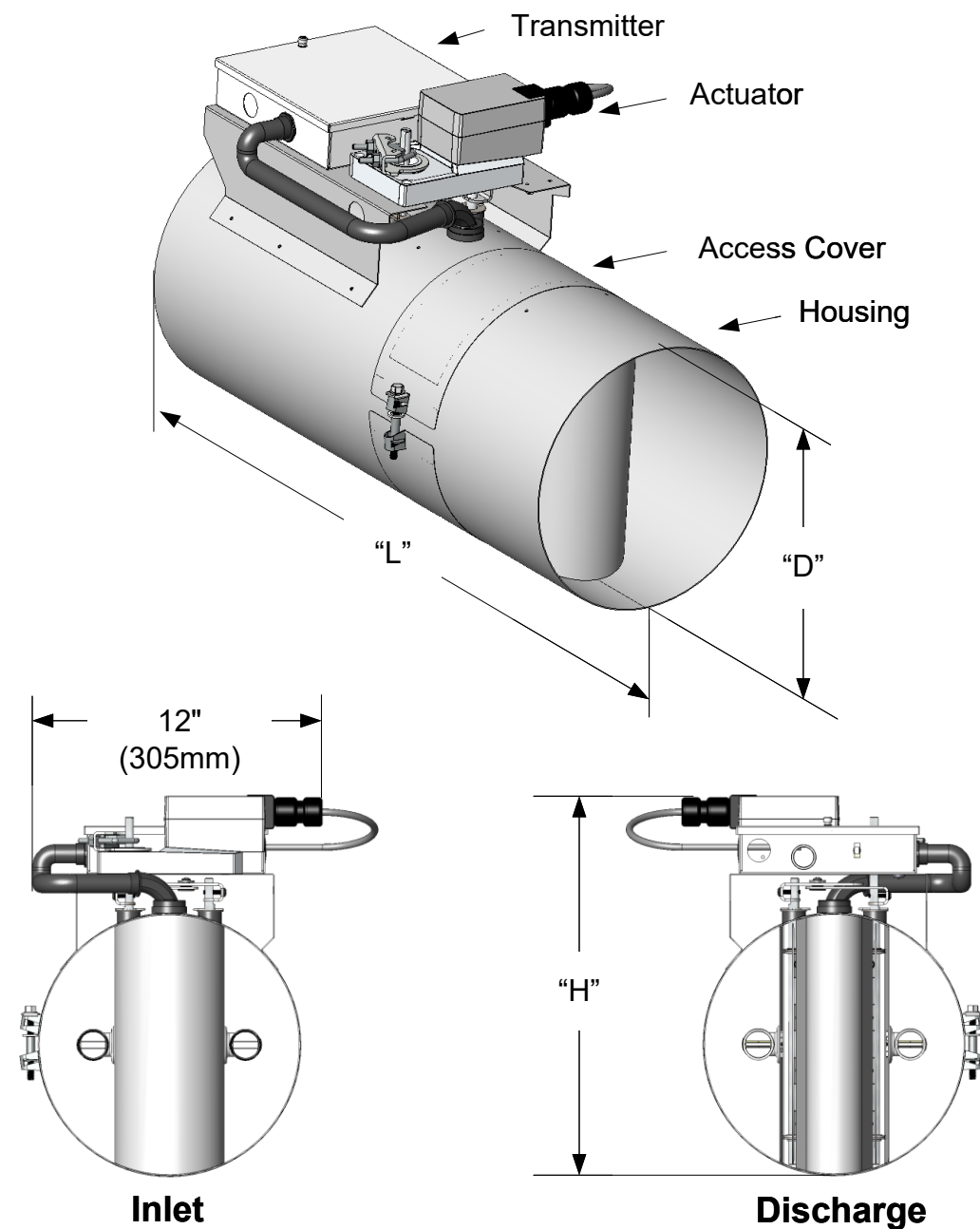
### AccuValve® Model AVT6000

THIS DOCUMENT IS SUBJECT TO CHANGE WITHOUT NOTICE.  
 THIS DOCUMENT OR THE CONTENTS THEREOF SHALL NOT BE MODIFIED WITHOUT PRIOR WRITTEN PERMISSION BY ACCUTROL LLC.

DWG. NO:	AVT6000 SUBMITTAL DWG		
REVISION:	P	ECN:	3038
REV. DATE:	2-13-25	SHEET:	1 OF: 5

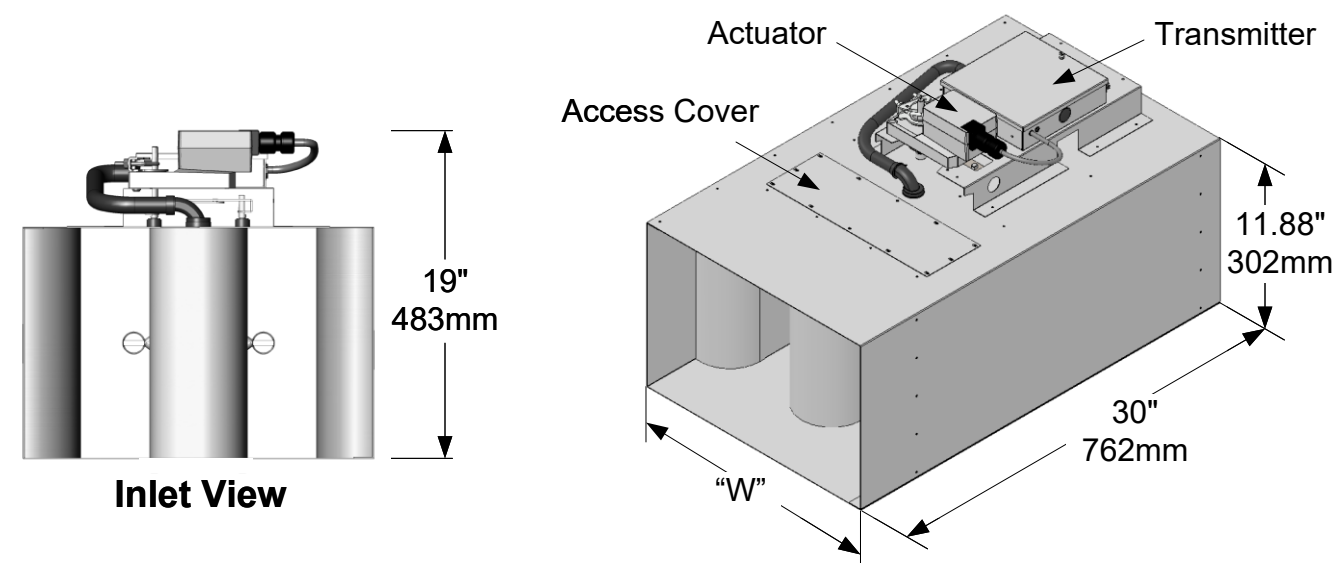
# ROUND VALVE

- AVT6X06-XX
- AVT6X08-XX
- AVT6X10-XX
- AVT6X12-XX
- AVT6X14-XX

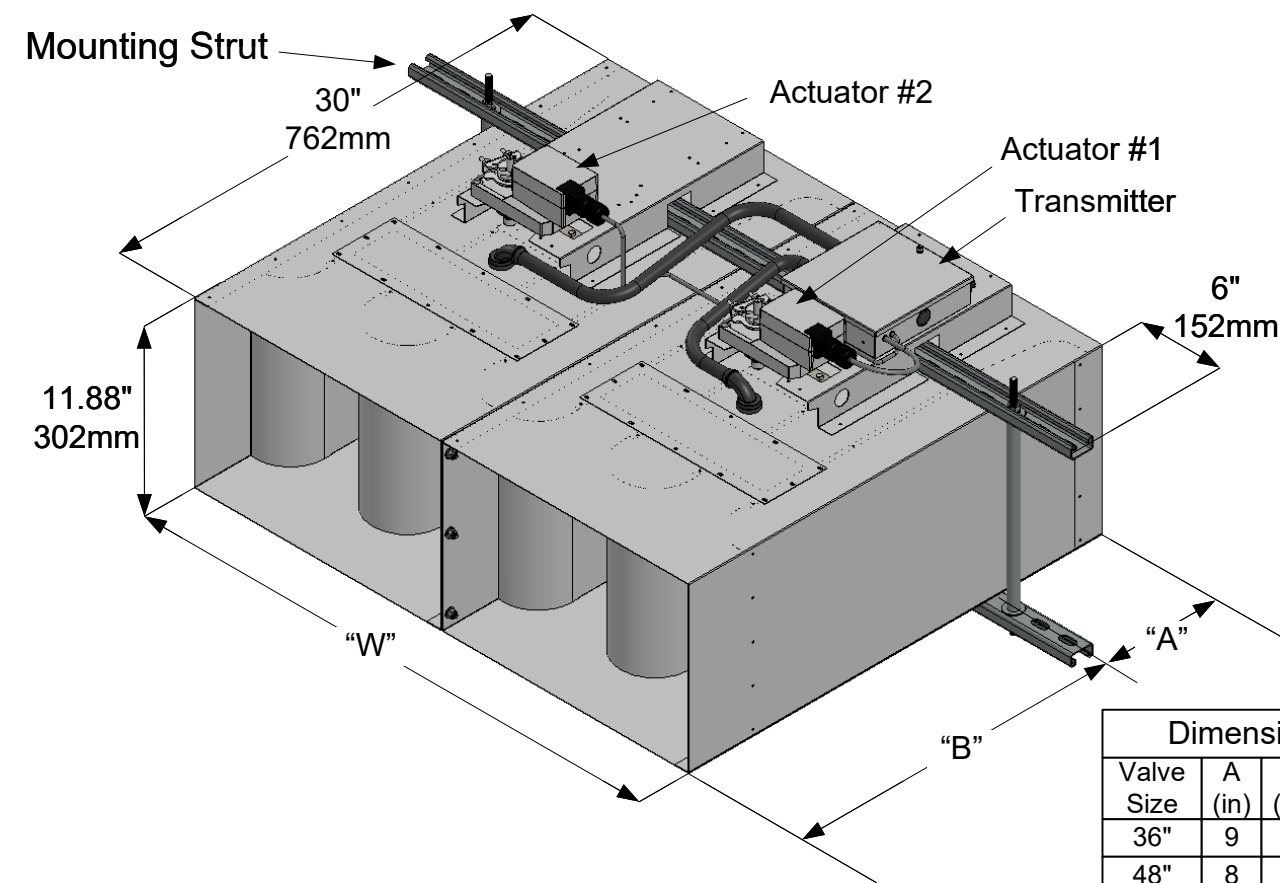


# RECTANGULAR VALVE

- AVT6X18-XX
- AVT6X24-XX



- AVT6X36-XX
- AVT6X48-XX



Dimension to Strut				
Valve Size	A (in)	A (mm)	B (in)	B (mm)
36"	9	229	21	533
48"	8	203	22	559

# ROUND VALVE: INSTALLATION INSTRUCTIONS

**⚠ WARNING:** Wear eye protection, protective gloves and clothing suitable for working with sheet metal which may have sharp edges.

1. Read all instructions prior to beginning installation.

**NOTE:** For detailed installation instructions, refer to the AccuValve® Installation & Operation Manual.

2. Verify the tag number located on the valve label matches the HVAC schedule.

3. Locate the duct section which the valve is servicing and select a suitable mounting location for the valve.

**NOTES:** The AccuValve® does not require straight inlet duct runs to operate properly, however it's always best to locate the valve away from transitions and bends to minimize impact on system static pressure. Be sure to select a location that will provide a minimum clearance of 14 inches (356 mm) unobstructed access to the transmitter, actuator and valve access cover. The AccuValve® is not position sensitive. It can be installed in any plane or rotational axis without having impact on the performance.

4. Provide an opening in the selected duct section sized appropriately for the valve being installed.

**NOTE:** A slip-fit valve will require an opening approximately 2" (50.8 mm) smaller than the valve length, whereas a flanged valve will require an opening the same length as the valve. Reference Sheet 1 for valve dimensions.

5. Install duct hangers within 12 inches (305 mm) from each end of the valve. Reference Sheet 1 for valve weights.

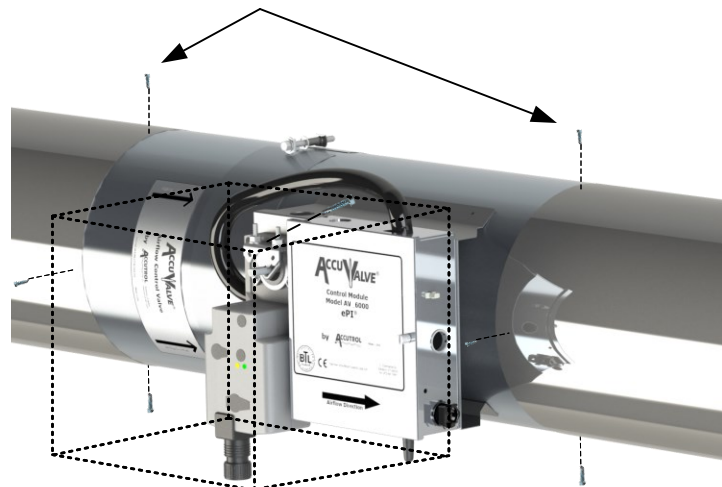
**⚠ WARNING:** Use duct hangers and hardware designed to support the total load of valve and associated duct sections. Failure to do so may result in serious personal injury or death.

6. Install the valve into the duct in accordance with the Airflow Direction Label located on the valve. Position the valve for easy access to the transmitter side then secure to duct per the appropriate Figure below.

**NOTE:** Screws, nuts, fasteners, duct sealant, hangers, and gaskets are not provided by Accutrol LLC.

## Standard Slip-fit Valve Secured Using Tek Screws

Seal joints using duct sealant and secure valve to duct at both ends using Tek screws.



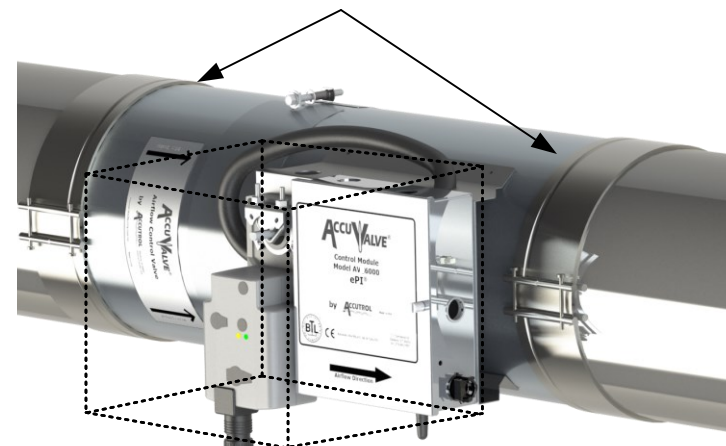
14" (356mm)  
Keep-Out Zone

**Figure 1**

## Standard Slip-fit Valve Secured Using Draw Bands

(Draw Bands are Sold Separately)

After sealing joints with appropriate type of tape, secure both ends using draw band clamps.



14" (356mm)  
Keep-Out Zone

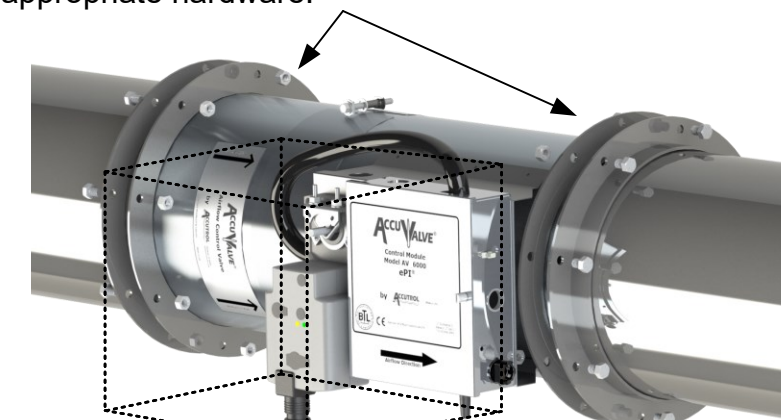
**Figure 2**

Reference Accutrol Draw Band Clamp Submittal Drawing for Details

## Flanged Valve "Option F" Secured Using Companion Flanges

(Companion Flanges are Sold Separately)

Install companion flanges to duct ends and secure to duct. Apply duct sealant and/or gasket to flange face. Install valve and rotate Vanstone flanges to align with bolt holes on the duct flanges. Secure flanges using appropriate hardware.



14" (356mm)  
Keep-Out Zone

**Figure 3**

Reference Accutrol Vanstone Flange Submittal Drawing for Details



## RECTANGULAR VALVE: INSTALLATION INSTRUCTIONS

1. Read all instructions completely before installing the valve.

**! WARNING:** Wear eye protection, protective gloves and clothing suitable for working with sheet metal which may have sharp edges.

2. Verify the tag number located on the valve label matches the HVAC schedule.

3. Select optimum mounting location for the valve.

**NOTE:** The AccuValve® does not require straight inlet duct runs to operate properly, however it's always best to locate any duct device away from transitions and bends to minimize impact on system static pressure.

4. Allow a minimum clearance of 14 inches (356 mm) unobstructed access to the transmitter, actuator and valve access cover.

**NOTE:** Rectangular valves are normally installed with the "access side" facing downwards for easy access. However, the AccuValve® is not position sensitive. It can be installed in any plane or rotational axis without having impact on the performance.

5. To support the weight of the valve, install duct hangers within 12 inches (305 mm) of valve connections. The 12x36" and 12x48" valves include an integral mounting strut which shall be used to support the valve in addition to the duct hangers. Reference Sheet 1 for valve weights.

**! WARNING:** Use duct hangers and hardware designed to support the total load of the valve and associated duct sections. Failure to do so may result in serious personal injury or death.

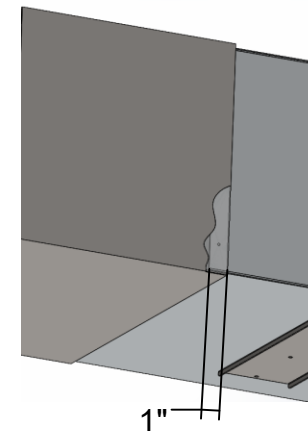
6. After the duct section is properly supported to carry the weight of the valve, install valve into the duct in accordance with the Airflow Direction Label located on the valve. Position valve so the transmitter, actuator and access cover are easily accessible. For 12x36" and 12x48" valves, attach the integral mounting bracket to threaded rod or duct hangers capable of supporting valve weight.

7. Reference the appropriate diagram to the right for installation details.

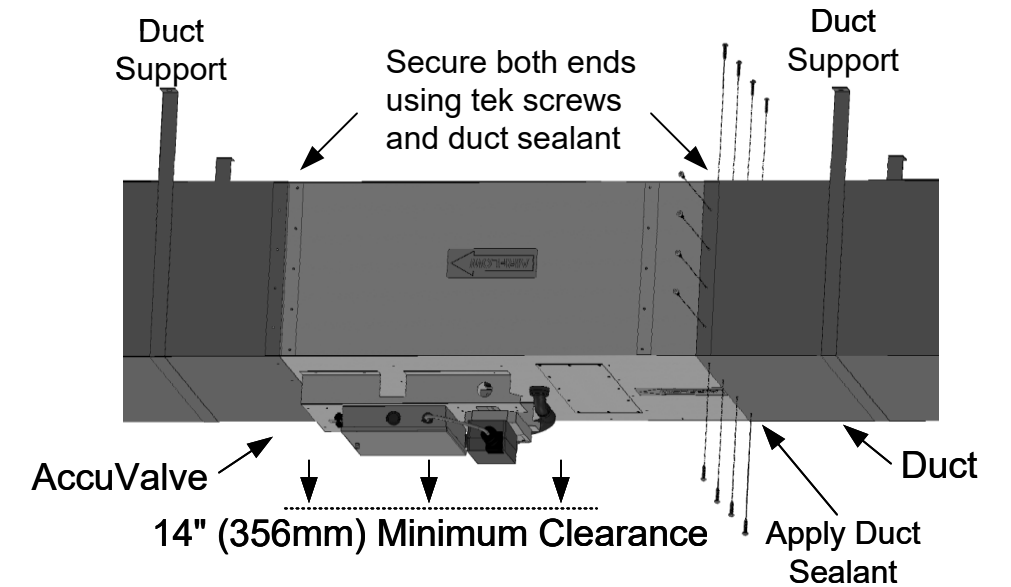
**NOTE:** Screws, nuts, fasteners, duct sealant, hangers, companion flanges and gaskets are not provided by Accutrol LLC.

## RECTANGULAR VALVE: INSTALLATION DIAGRAMS

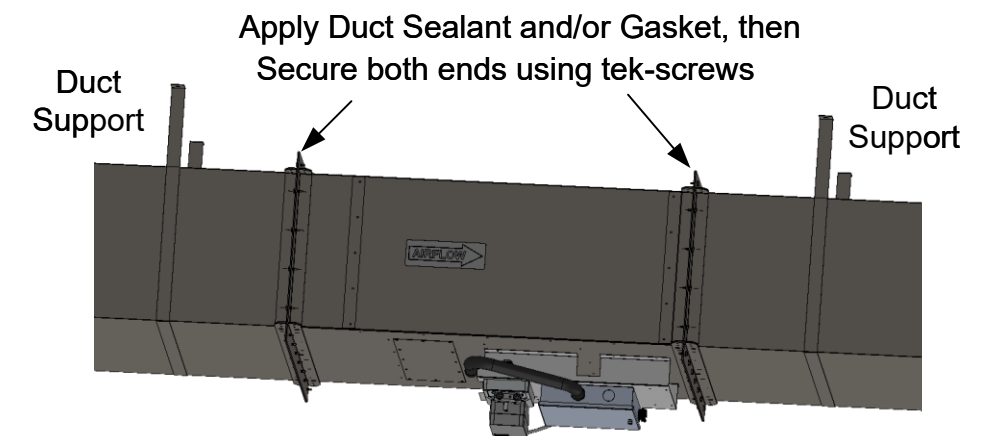
**Figure 1**  
Standard Slip-fit  
Valve Using Tek  
Screws



For slip-fit applications valve must be inserted at least 1" into ductwork to cover open holes on valve housing.

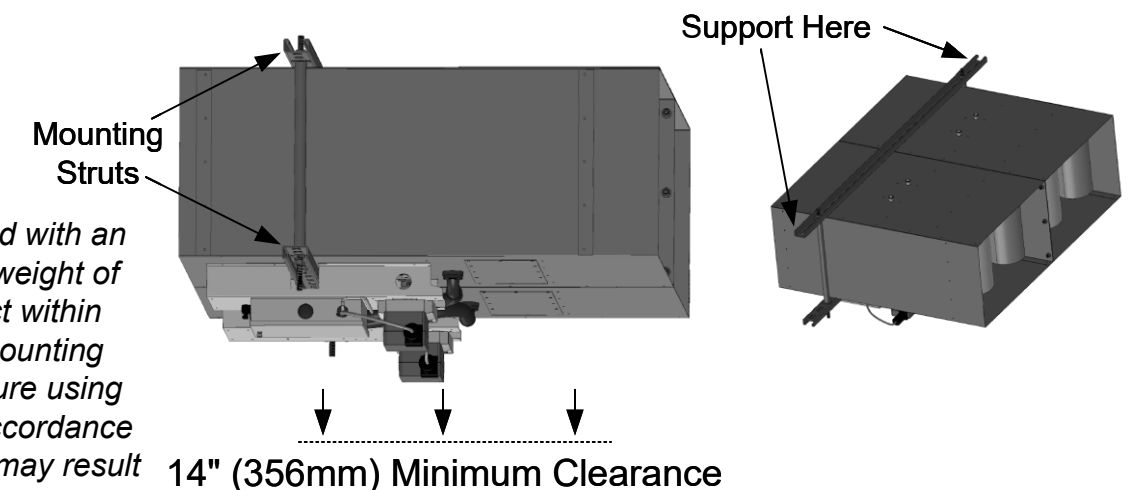


**Figure 2**  
Flanged Valve  
"Option F" Using  
Companion Flanges

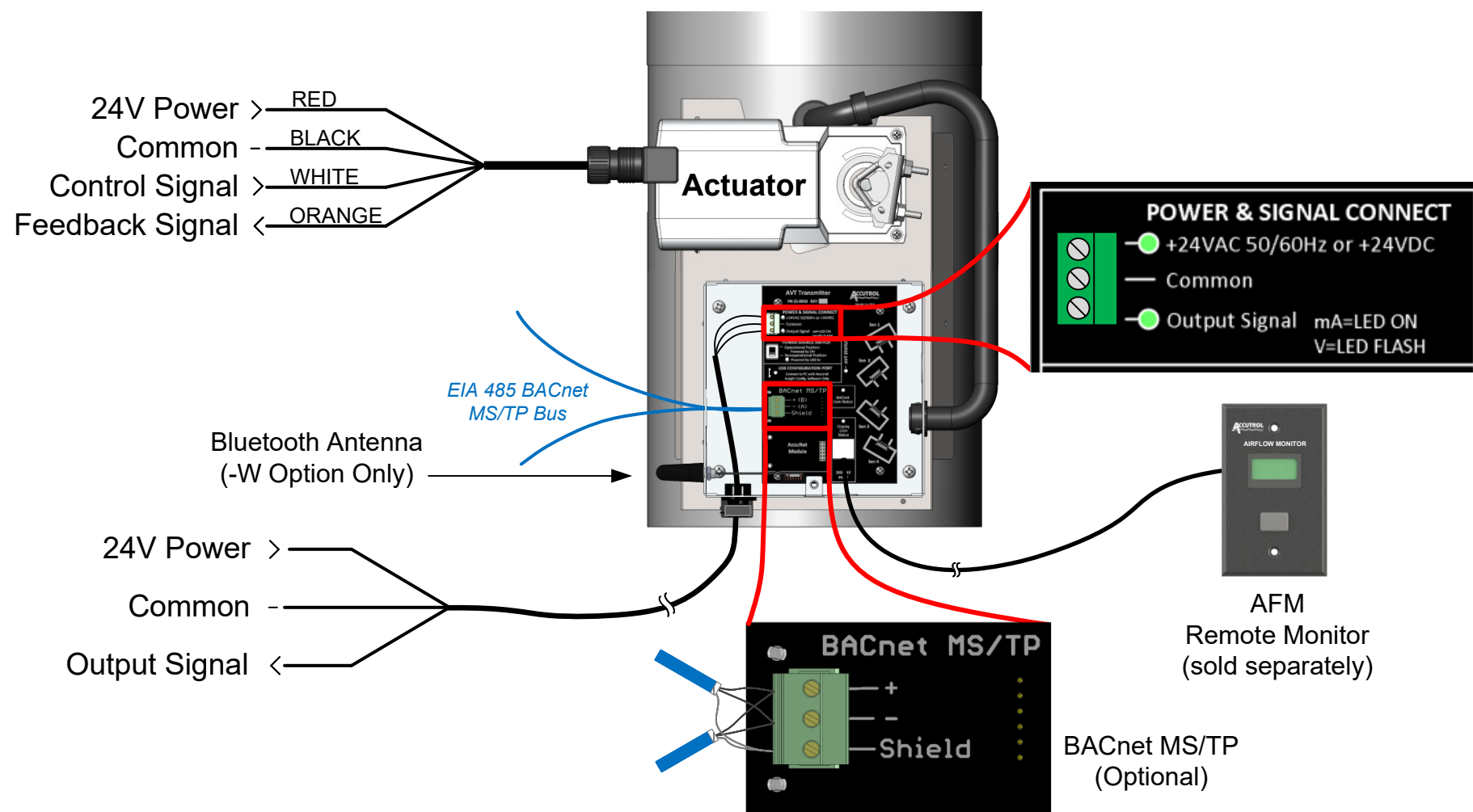


**Figure 3**  
12x36" and  
12x48" Valves

**! WARNING:** Dual valves are provided with an integral mounting strut to help support the weight of the valve. In addition to supporting the duct within 12" of the valve, each end of the integral mounting strut shall be secured to the building structure using properly rated hardware and methods in accordance with local building codes. Failure to do so may result in serious personal injury or death.



# WIRING INSTRUCTIONS



## Transmitter and Actuator

Connect the power and signal wires to the Actuator and Transmitter per the diagram. For more details on the actuator, reference the appropriate actuator submittal drawing listed in the table below.

**CAUTION:** Maintain polarity if the power source is used to power multiple devices otherwise equipment may be damaged.

**CAUTION:** Do not use the transmitter enclosure as a junction box. The only wires entering the transmitter enclosure shall be wires connected to the transmitter otherwise equipment may be damaged.

## Optional AccuNet Module

Reference AccuNet Field Manual.

## Optional BACnet MS/TP Module

Connect the 2-wire EIA 485 BACnet MS/TP bus to the AVT6000 transmitter per the diagram. Network bias and EOL termination are not provided by the AVT6000.

## Optional Wireless Bluetooth Module

Reference Wireless Bluetooth Field Manual.

## Remote Monitor AFM (Sold Separately)

Plug one end of the factory cable into the back of the remote monitor and plug the other end into the AVT6000 Display Port.

# TRANSMITTER ELECTRICAL SPECIFICATIONS

**Power Supply:** 24 VAC +/- 20% 50/60 Hz, 4 VA max (8.5 VA max with remote monitor)  
24 VDC +/- 10% 1.5 W max (3.5 W max with remote monitor)

**Output Signal:** 0-20mA, 4-20mA, 0-10V, 2-10V, 0-5V, or 1-5V (Software Config.)  
12-bit Resolution

Capable of driving 1K-ohm load

**Configuration:** USB Type C Connector, Wireless Bluetooth (Optional)

**Power Source Switch:** Selects alternate power source for configuration when main power is not available by drawing 5V from PC connected to USB config. port

**BACnet MS/TP (Optional):** EIA 485 2-wire BACnet MS/TP, Galvanically Isolated  
Baud Rates 9600, 19200, 38400, 76800 and 115200  
1/8 Unit Load Receiver Input Impedance

Network bias and EOL Termination not provided within the Transmitter

**Remote Monitor (Sold Separately):** LCD, 2 lines x 8 characters with white LED backlight  
Includes USB Configuration Port and Factory Cable

**Terminal Plugs:** 3-position, vertical pluggable, screw on top, wire size range 12-30 AWG

**Note:** Consult local electrical building codes to determine wire size required for application.

**WARNING:** During installation, testing, servicing and troubleshooting of this product, it may be necessary to work with live electrical components. This work shall be performed by a licensed electrician or qualified individual who has been properly trained in handling live electrical equipment. Failure to follow all electrical safety precautions when exposed to live electrical components may result in serious injury or death.

# ACTUATOR ELECTRICAL SPECIFICATIONS

For actuator specifications, reference the Actuator Drawing per table below.

AVT6000 Model	Actuator Type	Actuator Drawing #
AVT6XXX-02	0-10V, Fail Last Position	20-0008
AVT6XXX-03	2-10V, Fail Last Position	20-0009
AVT6XXX-04	0-10V, Fail Open or Closed	20-0010
AVT6XXX-05	2-10V, Fail Open or Closed	20-0011
AVT6XXX-07	2-10V, Fail Last Position	20-0057