

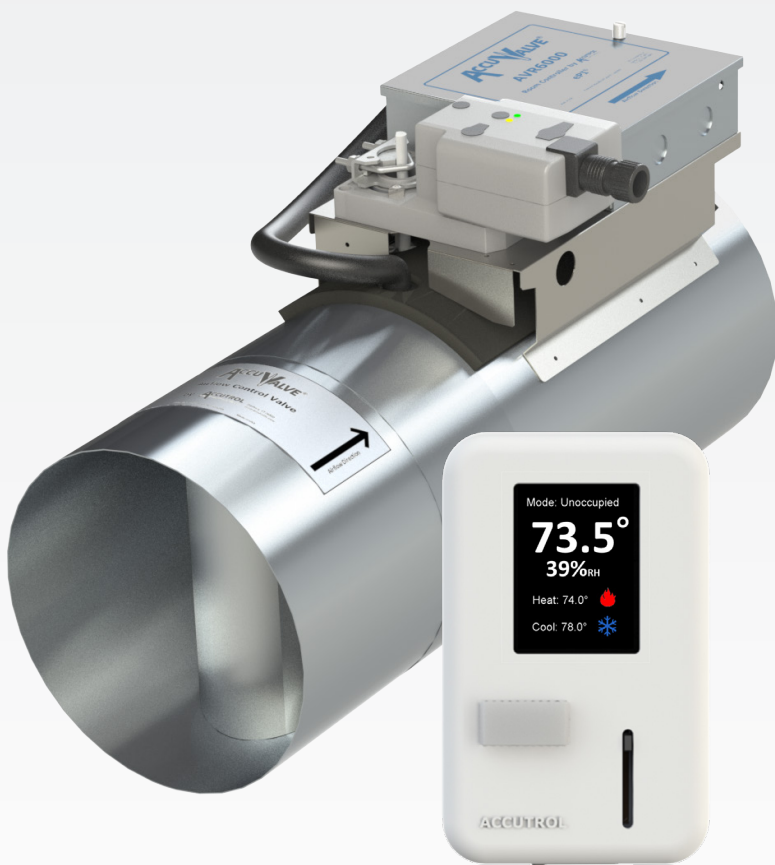

AVR6000

US Patents 6,991,177 & 7,543,759

AccuValve with Room Temperature and Airflow Tracking Control



Innovative features for the AVR6000!

- Intuitive Graphical User Interface Dashboard
- Room Temperature Control Capability
- Reheat Valve Control Capability
- Supply and Exhaust/Return Airflow Tracking
- BACnet® is Software Selectable (no dip switches)
- Bluetooth® Configuration Optional
- ARS Room Temperature / RH Sensor

Plus, these standard AccuValve features...

- Exceptionally Low Pressure Drop
 - Design System Pressure – as low as 0.05" (12.5 Pa)
- Electronic Pressure Independence
- Fast Speed of Response
- True Airflow Feedback
- No Straight Run Requirements
- Linear Control Response
- High Accuracy and Turndown
- Can be Mounted in Any Position
- Native BACnet® MS/TP
- 5-Year Manufacturer Warranty

Manufactured in the USA.



The Accutrol AVR6000 is an electronically pressure independent AccuValve®. It takes the revolutionary design of the exceptionally low pressure drop AccuValve and builds temperature and airflow control into the electronics. The AVR6000 is designed for critical tracking airflow control in laboratories and other specialized areas where fast speed of response and precise airflow measurement is required. The integral native BACnet® MS/TP allows direct communication to the Building Automation System (BAS) where desired.

Features & Benefits

The AccuValve's ISO 9001:2015 certified, award winning design incorporates:

Exceptionally Low Pressure Drop

AccuValve's award winning design incorporates a streamlined compression section and a carefully designed static regain section. These features provide lower pressure drop, lower noise level and better flow measurement conditions than any other available technology.

True Airflow Measurement

The integral high accuracy vortex airflow sensing provides high turndown while maintaining accuracies of 5% of reading over the flow range, ensuring precise airflow control.

No Straight Run Requirements

There are no straight duct runs required before or after the valve, making application of the valve very simple. The air compression in the valve provides laminar airflow throughout the airflow range providing repeatable airflow measurement regardless of inlet or outlet conditions.

ASHRAE Standard 90.1 Compliant without need for additional hardware

ASHRAE Standard 90.1 calls for the reset of the static pressure setpoint in VAV systems equipped with DDC controls. The AccuValve design allows the Building Automation System to provide this benefit to the owner without the requirement of any additional hardware or complexity. This is unique to the AccuValve for critical environments.

Simple Layout and Installation

All parts of the AccuValve are accessible from the front of the valve simplifying installation requirements. In addition, the valve can be mounted at any angle and rotated 360°.

Intuitive Insight Software

The AVR6000 also incorporates a simple and intuitive graphical user interface which enables the user to configure the valve for their specific airflow and temperature control requirements. Accutrol's Insight software, provided free of charge, insures that the owner is not required to contact the manufacturer of the airflow control system when changes are required in the field.

BACnet®

The integral, native BACnet® MS/TP allows direct communication to the Building Automation System (BAS) where desired.

AVR Provides

- Four user-defined modes to meet the most demanding energy conservation requirements
- Accurate volumetric flow tracking control to maintain precise room pressurization

ARS Room Sensor Provides

- Accurate thermistor-based temperature sensor
- Relative humidity sensor
- Optional digital display
- Optional setpoint slider
- Optional motion sensor
- Communications to minimize A/O

Bluetooth® Configuration Option

The AVR6000 is available with a Bluetooth® configuration option, which alleviates the requirement for a USB connector when accessing the airflow valve via Accutrol's Insight graphical user interface software.

Dual Maximum Control (DMC) Logic

- First Stage of Heating Resets Discharge Air Temperature
- Second Stage of Heating Increases the Airflow Rate to Heating Maximum Airflow Setpoint
- DMC Logic Combined with the AccuValve's provide the most energy efficient solution available



Accutrol's Insight Software Dashboard

The AVR adds room temperature control and tracking control to the AccuValve package.

AVR Standard Applications

App 1

Supply with Reheat Control

App 1 is used for rooms that require a single supply valve where precise airflow and room temperature control are required. The AVR AccuValve controls the supply airflow volume and reheat valve modulation based on the parameters configured using the AccuValve Insight Software or via BACnet. A duct temperature sensor can be included for applications that require reheat discharge air temperature control.

Room temperature / RH measurement is provided by the Accutrol ARS room sensor module, which is available with an

optional display, setpoint adjustment and motion sensor. The ARS also includes a USB port that is used for connecting a computer equipped with the AccuValve Insight Configuration Software.

The AVR can provide up to 4 preconfigured setpoint modes to maximize energy savings and accommodate application-specific sequences such as: occupied, unoccupied, decontamination, emergency. The AVR also includes Dual Maximum Logic to help meet the latest energy conservation standards including ASHRAE Standard 90.1 and California Title 24 criteria.

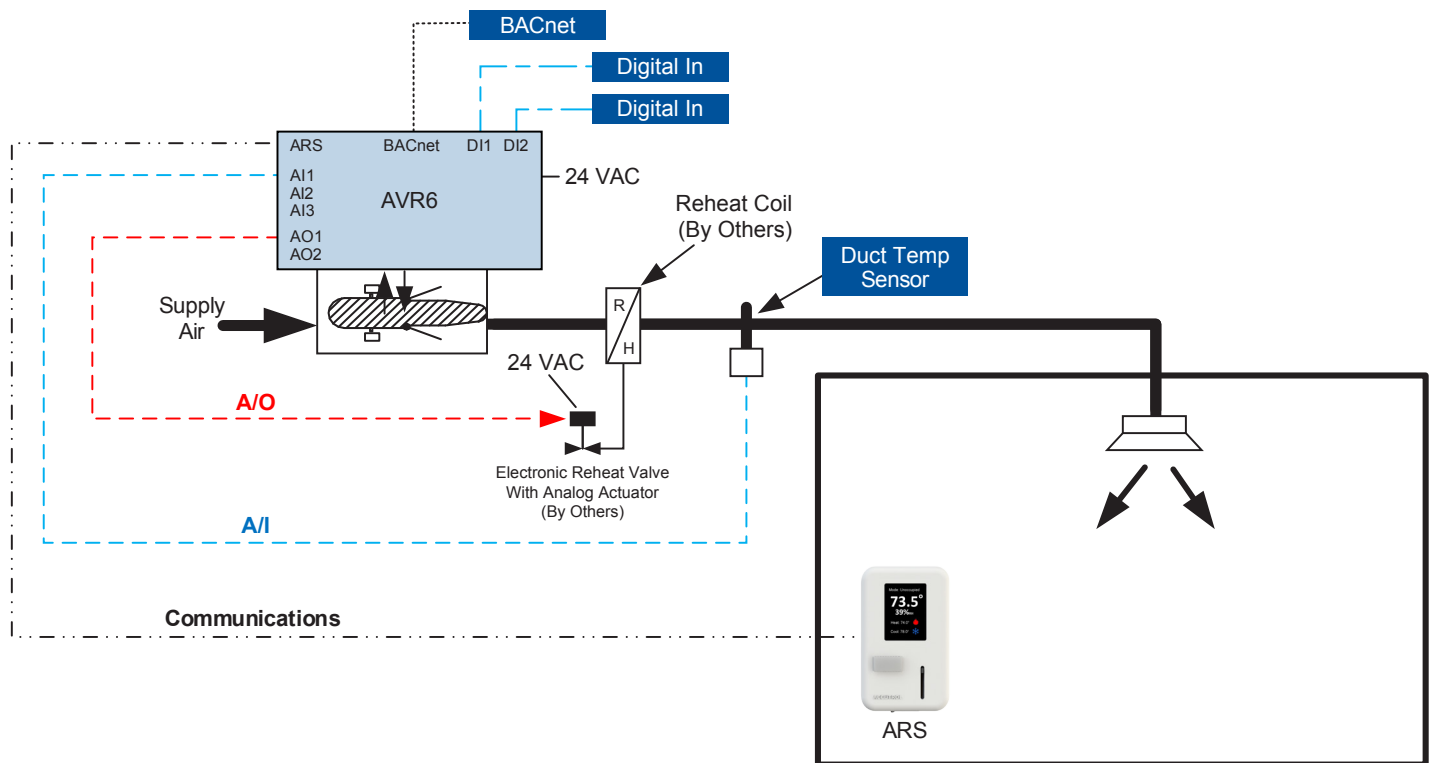

App1 – Single Supply AccuValve

AVR Standard Applications

App 2

Supply with Reheat Control and Tracking Exhaust/Return

App 2 is similar to App 1. However, the addition of an exhaust valve provides accurate volumetric airflow tracking control for maintaining precise room pressurization as the supply airflow

demand changes. The exhaust valve provided is an AVT AccuValve which is hardwired directly to the AVR supply valve for immediate and reliable response.

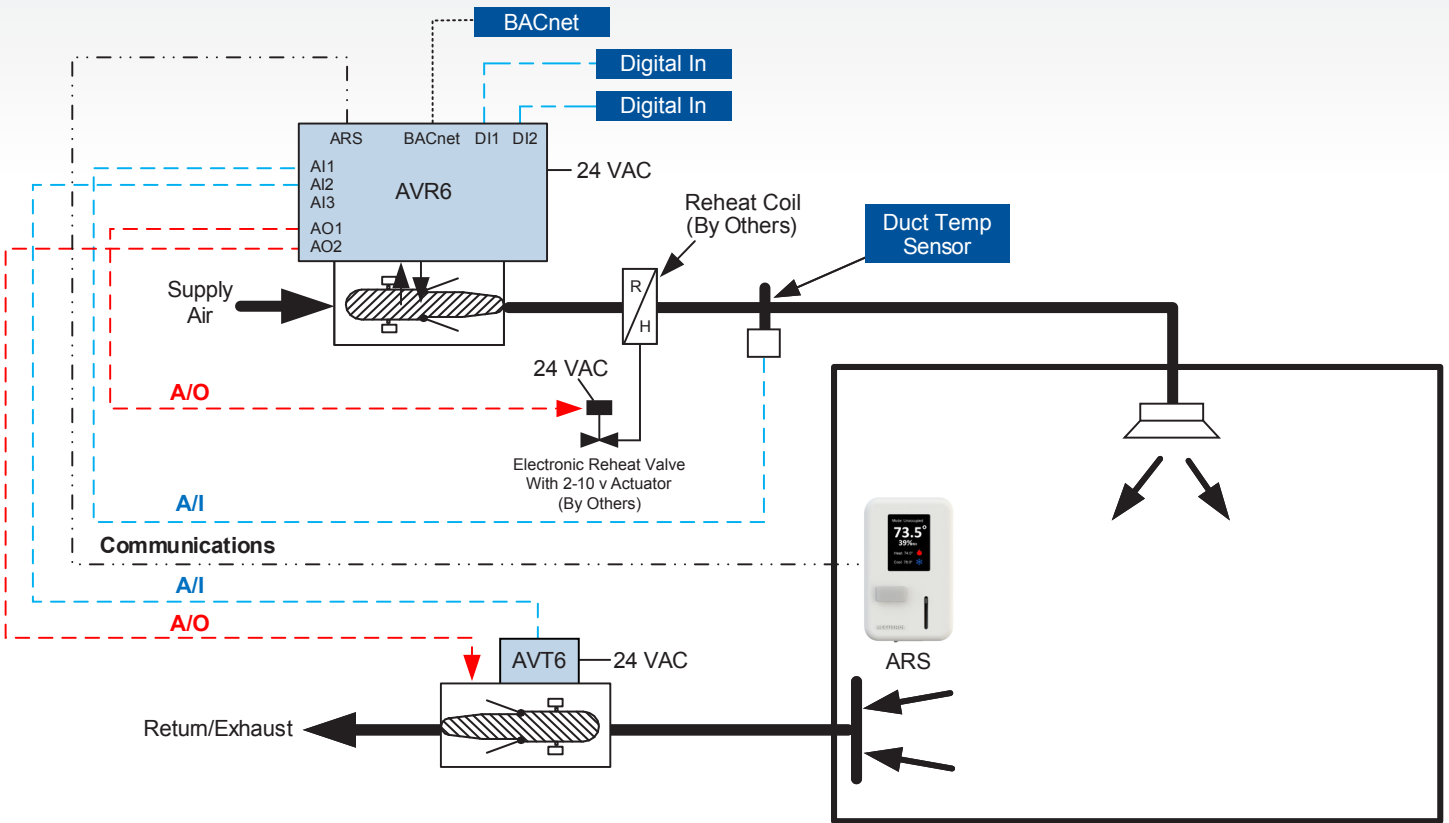

App 2 – One Supply and One Exhaust/Return

AVR Standard Applications

App 3

Supply with Reheat Control, General Exhaust and One Fume Hood

App 3 is similar to App 2 with the addition of a single fume hood or similar type of exhaust device located within the controlled room. Control of the fume hood exhaust valve is provided by an AVC6 AccuValve which sends the real-time fume

hood exhaust airflow volume to the AVR via a hardwired analog signal so the AVR can calculate the total exhaust airflow and provide tracking control to maintain precise room pressurization as the airflow demand changes.

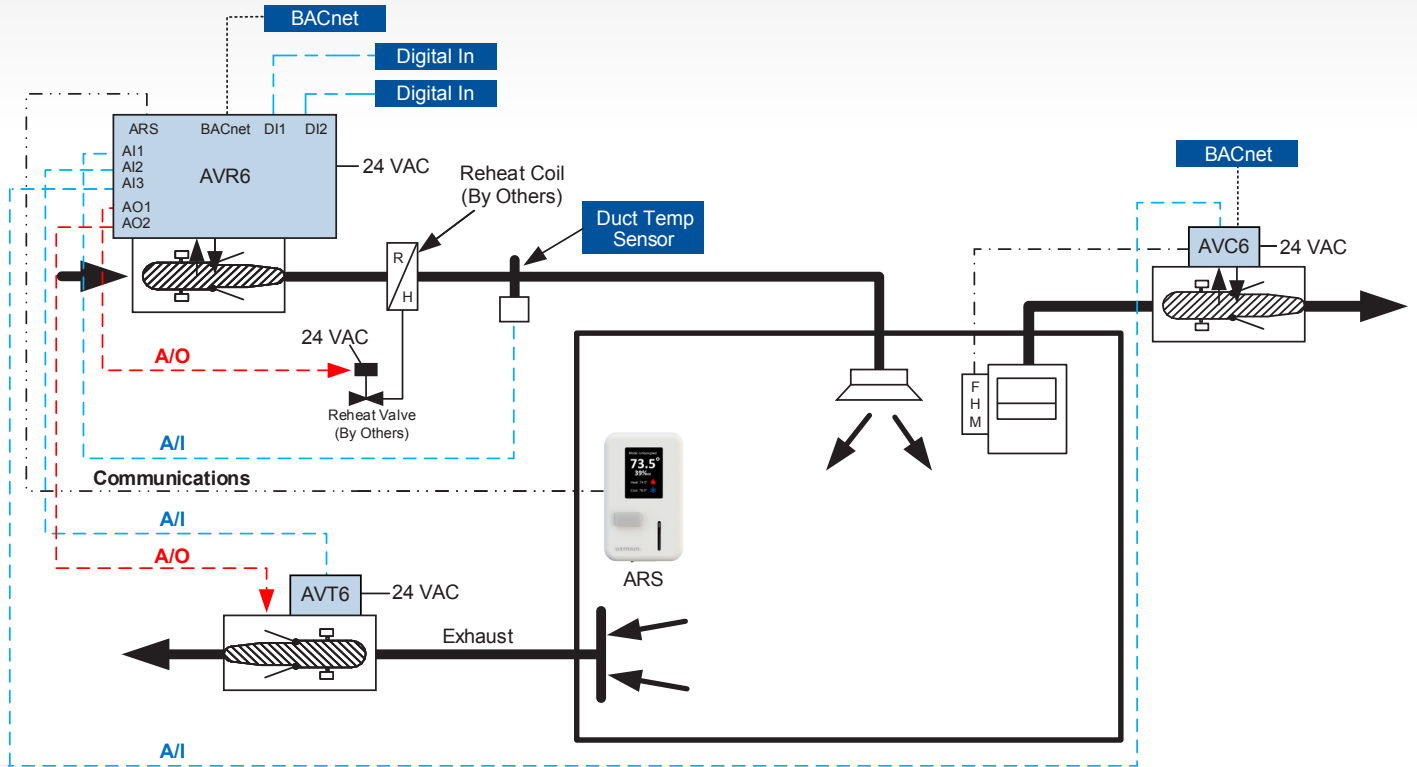

App 3 – One Supply, One Exhaust and One Fume Hood

AVR Standard Applications

App 4

Supply with Reheat, General Exhaust and More Than One Fume Hood

App 4 is identical to App 3 with the exception that multiple fume hoods or similar exhaust devices are located in the room. Control of the additional fume hoods or other exhaust devices is provided by AVC AccuValves that are equipped with AccuNet communication modules. Each exhaust valve equipped with AccuNet will communicate their respective exhaust airflow over

the AccuNet and the total exhaust airflow is summed and provided to the AVR AccuValve with a hardware analog signal. Exhausts are summed using AccuNet to determine the total fume hood exhaust airflow. One fume hood AVC is used as the totalizer and sends an analog signal to the AVR which is added to the GE to determine the total exhaust from the laboratory.

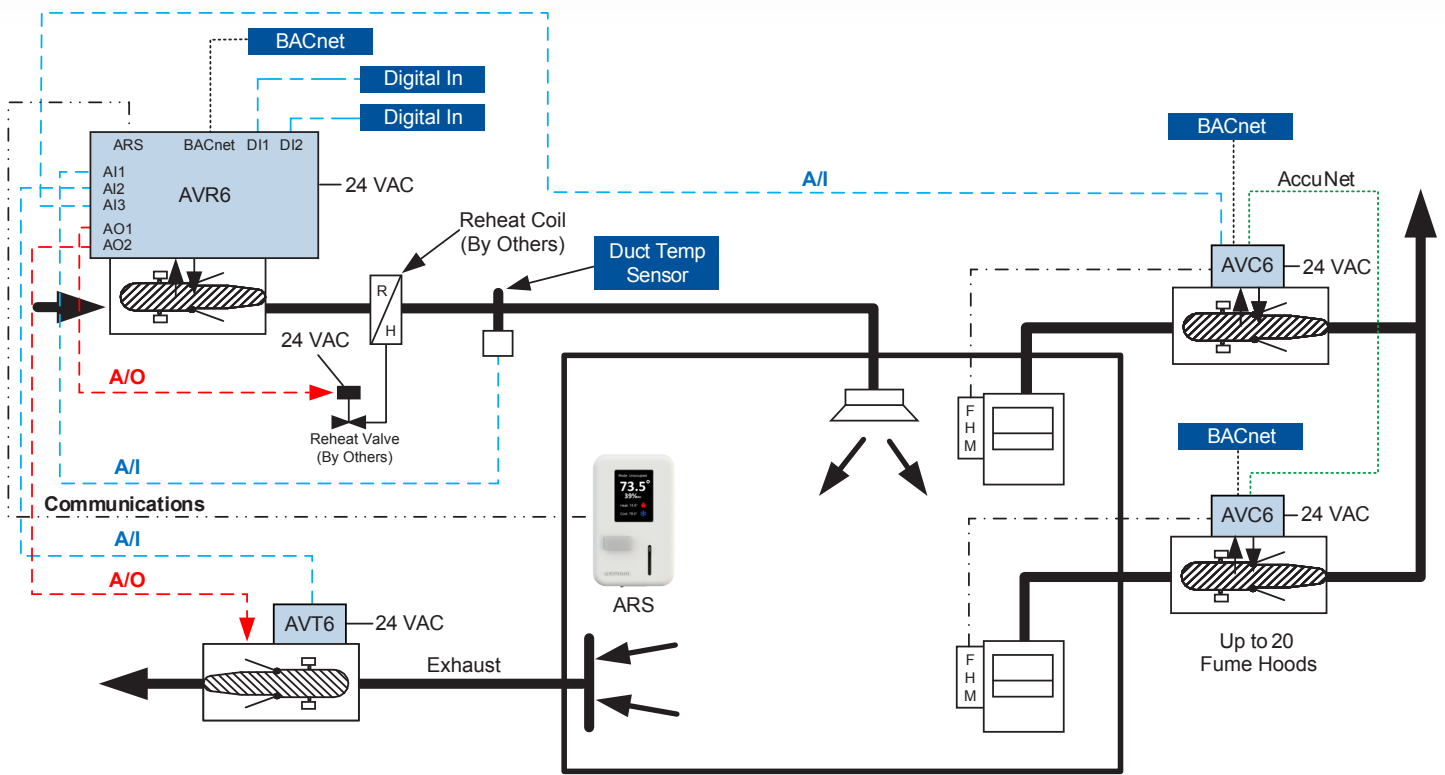

App 4 – One Supply, One GE and More Than One Fume Hood

Operating Pressure Selector

Valve Size (mm)	Eng Units	Airflow Range							
		Minimum	Maximum Design Airflow						Maximum
6" (152)	CFM	30	99	143	174	206	230	254	315
	L/S	14	47	67	82	97	108	120	149
	CMH	51	168	243	296	350	391	432	535
8" (203)	CFM	80	252	367	447	528	589	650	800
	L/S	38	119	173	211	249	278	307	378
	CMH	136	428	624	760	897	1000	1104	1359
10" (254)	CFM	120	428	606	733	860	958	1056	1300
	L/S	57	202	286	346	406	452	498	614
	CMH	204	727	1030	1245	1461	1627	1794	2209
12" (305)	CFM	180	591	840	1016	1192	1326	1461	1790
	L/S	85	279	396	479	563	626	690	845
	CMH	306	1004	1427	1726	2025	2253	2482	3041
14" (356)	CFM	250	979	1364	1624	1884	2079	2275	2750
	L/S	118	462	644	766	889	981	1074	1298
	CMH	425	1663	2317	2759	3201	3533	3865	4672
12"x18" (305x457)	CFM	260	1003	1437	1761	2086	2341	2596	3200
	L/S	123	473	678	831	984	1104	1225	1510
	CMH	442	1704	2441	2992	3544	3977	4411	5437
12"x24" (305x610)	CFM	350	1261	1812	2213	2614	2925	3237	4000
	L/S	165	595	855	1044	1234	1381	1528	1888
	CMH	595	2142	3079	3760	4441	4970	5500	6796
12"x36" (305x915)	CFM	520	2005	2875	3523	4172	4681	5191	6400
	L/S	245	946	1357	1663	1969	2209	2450	3020
	CMH	883	3407	4885	5986	7088	7954	8820	10874
12"x48" (305x1220)	CFM	700	2522	3625	4426	5228	5850	6473	8000
	L/S	330	1190	1711	2089	2467	2761	3055	3776
	CMH	1189	4285	6159	7520	8882	9940	10998	13592
Operating Pressure	" W.C.	< 0.01	0.05	0.1	0.15	0.2	0.25	0.3	0.45
	Pa	< 2.5	12.5	25	37.5	50	62.5	75	112.5

BEST ←

GOOD

Optimum Energy Efficiency

* Minimum operating pressure when tested in accordance with ANSI/ASHRAE 130-2008

For further assistance in making your AccuValve selections, please refer to the AccuValve Selection Guide for Operating Pressure. An AccuValve selection tool for iPhone, iPad and Android devices is also available to assist with AccuValve selections.

Specifications

ELECTRICAL

Input Power 24VAC $\pm 20\%$ 50/60Hz (class 2 power source)
24VDC $\pm 10\%$

Actuator Type	Maximum Power Requirements	
	6"-24" Valve	36" & 48" Valve
3 or 5	30VA or 17W	53VA or 30W
7	13VA or 7W	19VA or 12W

Dedicated Analog Inputs

AI-1 (DTS)
Supply Air Discharge Temperature Signal

Signal Type Software selectable
Voltage 0-10v range, input impedance = 100K ohms
Current 0-20mA range, input impedance = 500 ohms
Resistance 10K Type III NTC thermistor

AI-2 (GEV)
General Exhaust Airflow Volume Signal

Signal Type Software selectable
Voltage 0-10v range, input impedance = 100K ohms
Current 0-20mA range, input impedance = 500 ohms

AI-3 (FHV)
Fume Hood / Other Exhaust Airflow Volume Signal

Signal Type Software selectable
Voltage 0-10v range, input impedance = 100K ohms
Current 0-20mA range, input impedance = 500 ohms

Dedicated Digital Inputs

2 dry-contact inputs
(for initiating setpoint sequences)

Dedicated Analog Outputs

AO-1 (RHV) Reheat Valve Control Signal

Signal Type Software selectable
Voltage 0-10V, 2-10V, 0-5V or 1-5V
Current 0-20mA or 4-20mA

AO-2 (GEV) General Exhaust Control Signal

Signal Type Software selectable
Voltage 0-10V, 2-10V, 0-5V or 1-5V
Current 0-20mA or 4-20mA

Alarm Relay Output

DPDT Relay with Opposing NC/NO Contacts
Rated Load 1A @ 30VDC or 0.3A @ 125VAC

Network

BACnet MS/TP EIA 485 2-wire
¼ Unit load receiver impedance
Network bias and termination are not provided internally by the AVR control module

Configuration Port

PC Connection with AccuValve Insight Software
USB "C" type communications port
Optional Wireless Bluetooth®

Device Port

Accutrol Room Sensor
RJ-45 port for factory-cable connection

Terminal Blocks

Removable vertical plugs, 2 & 3 position
Wire size range 12-30 AWG

Electromagnetic

2014/30/EU, EMC Directive
Compatibility EN61236-1:2013
2014/53/EU, Radio Equipment Directive
EN301489-1, V1.9.2:2011
ETSI EN301489-1, V2.2.0:2017
ETSI EN301489-3, V1.6.1:2013/V2.1.1:2017
ETSI EN301489-17, V2.2.1:2012/V3.2.0:2017

Product Safety

2014/35/EU, Low Voltage Directive
EN61010-1:2010/A1:2019/AC:2019

AIRFLOW PERFORMANCE

Airflow Accuracy $\pm 5\%$ of reading or 5 CFM (2 L/S; 8 CMH), whichever is greater

Speed of Response < 1 second (< 2 seconds for standard actuator)

Shut-off Leakage Rate @ 3"wc valve DP Standard round valves
(size 06 through 14) <1.5% FS max.

Round valves with blade seals
(size 08 through 14) <0.5% FS max.

Standard rectangular valves
(size 18 through 48) <2% FS max.

Rectangular valves with blade seals
(size 18 through 48) <1% FS max.

Max. Operating Pressure 3"wc differential pressure across valve

Failure Mode Fail Last Position or Fail Open/Closed
(selectable by model code)

TEMPERATURE PERFORMANCE

Room Temperature Measurement

Range 32° F to 132° F (0° C to 56° C)

Resolution 0.02° F (0.01° C)

Accuracy $\pm 0.25^\circ$ F ($\pm 0.14^\circ$ C)

Supply Duct Discharge Temperature Measurement

Range 47° F to 147° F (8° C to 64° C)

Resolution 0.1° F (0.06° C)

Accuracy $\pm 0.25^\circ$ F ($\pm 0.14^\circ$ C)

RELATIVE HUMIDITY MEASUREMENT

Range 0 to 100% RH

Resolution 0.02° RH

Accuracy $\pm 2\%$ typical, $\pm 2.5\%$ maximum

ENVIRONMENTAL

Temperature

Air Stream -20° to 165° F (-29° to 74° C)

-20° to 375° F (-29° to 190° C)
for high temperature SS model only

Ambient -20° to 125° F (-29° to 52° C)

Storage -40° to 165° F (-40° to 74° C)

Humidity 0% to 90% non-condensing

MATERIALS OF CONSTRUCTION

Valve Housing Aluminum (16 Gauge)
304SS (20 Gauge)
316SS (20 Gauge)

Shafts 316SS

Shaft Bearings Teflon®

Seals EPDM with aluminum valves
Viton with stainless steel valves

Airflow Sensors Polycarbonate plastic, UL94-VO
Polycarbonate plastic, UL94-VO
303SS for High Temperature 304SS

Control Module Enclosure 16 Gauge aluminum

Ordering Guides

Please see the following page for Ordering Guides.

AVR6000 AccuValve® Ordering Guide



Valve Housing Material

- 2** = 304SS, 20 Gauge
- 3** = 316SS, 20 Gauge
- 4** = Aluminum, 16 Gauge
- 6** = High Temperature, 304SS, 20 Gauge

Size

- 06** = 6" Diameter
- 08** = 8" Diameter
- 10** = 10" Diameter
- 12** = 12" Diameter
- 14** = 14" Diameter
- 18** = 12"h x 18"w
- 24** = 12"h x 24"w
- 36** = 12"h x 36"w
- 48** = 12"h x 48"w

Options

- Blank = No Options
- F** = Flanges
- I** = Insulation*
- S** = Tight Shut-off**
- W** = Wireless Bluetooth® Configuration

*Insulation is not available for High Temperature valves
**Blade seals are standard on all 6" valves

Actuator Type

- 03** = Fail Last Position (FLP, High Speed)
- 05** = Fail Open/Close (FSP, High Speed)
- 07** = Fail Last Position, 2-10v (Standard Speed)

Additional Accutrol Product Reference

- ARS2 Room Sensor*
- ADS2 Duct Mounted Room Temperature and RH Sensor*
- DTS100 Duct Temperature Sensor*

Your representative is:

